

# **HITACHI**

## ***HD COLOR CAMERA*** **DK-H100**

### ***OPERATING INSTRUCTIONS***

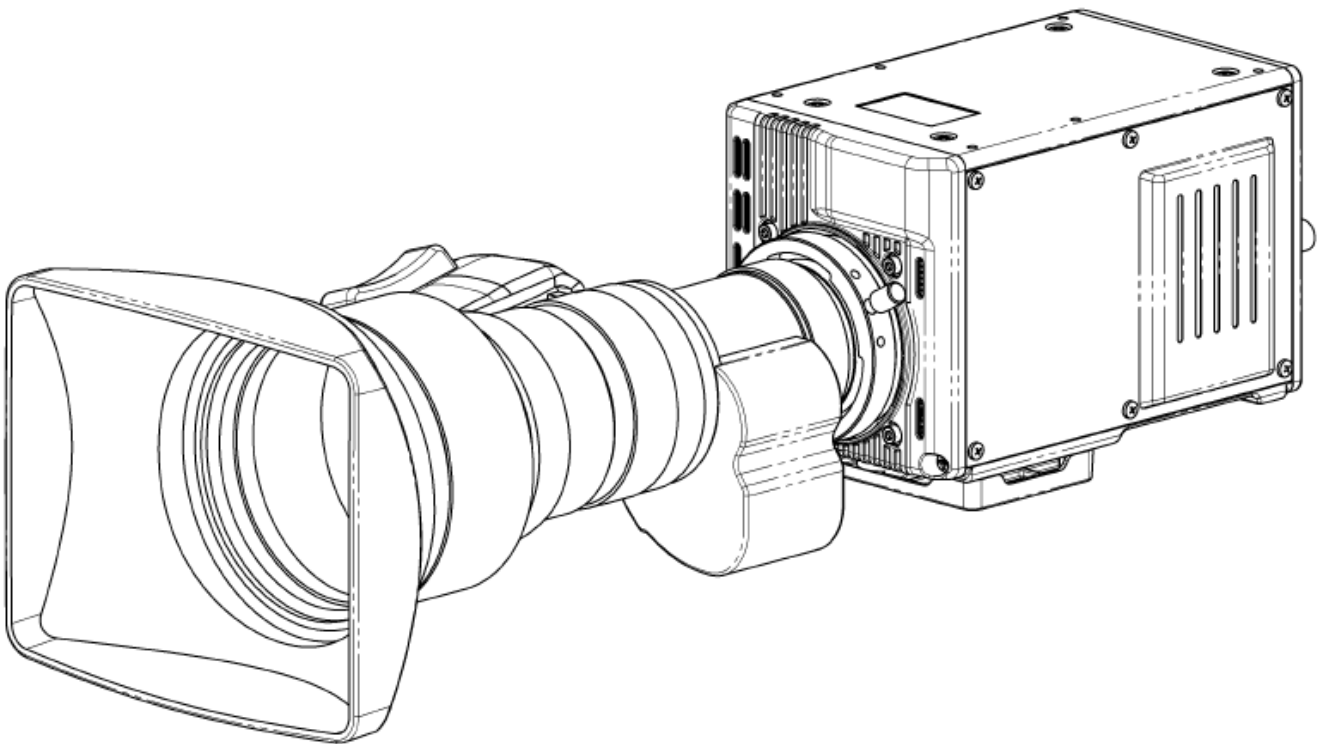

**Please read these operating instructions carefully for proper operation,  
and keep them for future reference.**

## **Hitachi Kokusai Electric Inc.**

**Note:** The model and serial numbers of your product are important for you to keep for your convenience and protection. These numbers appear on the nameplate located on bottom of the product. Please record these numbers in the spaces provided below, and retain this manual for future reference.

**Model No.** \_\_\_\_\_

**Serial No.** \_\_\_\_\_

# SAFETY INSTRUCTIONS

Carefully read all safety messages in this manual and safety Instructions on your equipment. Follow recommended precautions and safe operating practices.

## SAFETY ALERT SYMBOL



This is the "Safety Alert Symbol."

This symbol is used to call your attention to items or operations that could be dangerous to you or other persons using this equipment. Read these messages and follow these instructions carefully.

It is essential that you read the instructions and safety regulations before you attempt to assemble or use this equipment.

The definitions of signal words are as follows:



**WARNING:** Personal danger

Warning notes indicate any condition or practice, which if not strictly observed, could result in personal injury or possible death.



**CAUTION:** Possible damage to equipment

Caution notes indicate any condition or practice, which if not strictly observed or remedied, could result in damage or destruction of the equipment.



**NOTE:** Notes indicate an area or subject of special merit, emphasizing either the product's capabilities or common errors in operation or maintenance.

 **WARNING:** TO REDUCE THE RISK OF FIRE OR ELECTRIC SHOCK, DO NOT EXPOSE THIS COLOR CAMERA TO RAIN OR MOISTURE.

## AVERTISSEMENT

Afin d'éviter tout risque d'incendie ou d'électrocution, ne pas exposer l'appareil à la pluie ou à l'humidité.

Afin d'écartier tout risque d'électrocution, garder le coffret fermé.

Ne confier l'entretien de l'appareil qu'à un personnel qualifié.

## VORSICHT

Um Feuergefahr und die Gefahr eines elektrischen Schlags zu vermeiden, darf das Gerät weder Regen noch Feuchtigkeit ausgesetzt werden.

Um einen elektrischen Schlag zu vermeiden, darf das Gehäuse nicht geöffnet werden.

Überlassen Sie Wartungsarbeiten stets nur einem Fachmann.

# IMPORTANT SAFETY INSTRUCTIONS

## **1. Read Instructions**

All the safety and operating instructions should be read before the product is operated.

## **2. Retain Instructions**

The safety and operating instructions should be retained for future reference.

## **3. Heed Warnings**

All warnings on the product and the operating instructions should be adhered to.

## **4. Follow Instructions**

All operating and use instructions should be followed.

## **5. Cleaning**

Unplug this product from the wall outlet before cleaning. Do not use liquid cleaners or aerosol cleaners. Use a damp cloth for cleaning.

## **6. Attachments**

Do not use attachments not recommended by the product manufacturer as they may cause hazards.

## **7. Water and Moisture**

Do not use this product near water - for example, near a bath tub, wash bowl, kitchen sink, or laundry tub; in a wet basement; or near a swimming pool; and the like.

## **8. Accessories**

Do not place this product on an unstable cart, stand, tripod, bracket, or table. The product may fall, causing serious injury to a child or adult, and serious damage to the product. Use only with a cart, stand, tripod, bracket, or table recommended by the manufacturer, or sold with the product. Any mounting of the product should follow the manufacturer's instructions, and should use a mounting accessory recommended by the manufacturer.

## **9. Moving**

A product and cart combination should be moved with care.

Quick stops, excessive force, and uneven surfaces may cause the product and cart combination to overturn.

## **10. Ventilation**

Slots and openings in the cabinet are provided for ventilation and to ensure reliable operation of the product and to protect it from overheating, and these openings must not be blocked or covered.

The openings should never be blocked by placing the product on a bed, sofa, rug, or other similar surface.

This product should not be placed in a built-in installation such as a bookcase or rack unless proper ventilation is provided or the manufacturer's instructions have been adhered to.

## **11. Power Sources**

This product should be operated only from the type of power source indicated on the marking label. If company. For products intended to operate from battery power, or other sources, refer to the operating instructions.

## **12. Grounding or Polarization**

This product is equipped with a three-wire grounding-type plug a plug having a third (grounding) pin.

This plug will only fit into a grounding-type power outlet. This is a safety feature. If you are unable to insert the plug into the outlet, contact your electrician to replace your obsolete outlet. Do not defeat the safety purpose of the grounding-type plug.

## **13. Power-Cord Protection**

Power-supply cords should be routed so that they are not likely to be walked on or pinched by items placed upon or against them, paying particular attention to cords at plug, convenience receptacles, and the point where they exit from the product.

**14. Lightning**

For added protection for this product during a lightning storm, or when it is left unattended and unused for long periods of time, unplug it from the wall outlet. This will prevent damage to the product due to lightning and power-line surges.

**15. Overloading**

Do not overload wall outlets, extension cords or integral convenience receptacles as this can result in a risk of fire or electric shock.

**16. Object and Liquid Entry**

Never push objects of any kind into this product through openings as they may touch dangerous voltage points or short-out parts that could result in a fire or electric shock. Never spill liquid of any kind on the product.

**17. Inflammable and Explosive Substance**

Avoid using this product where there are gases, and also where there are inflammable and explosive substances in the immediate vicinity.

**18. Heavy Shock or Vibration**

When carrying this product around, do not subject the product to heavy shock or vibration.

**19. Servicing**

Do not attempt to service this product yourself as opening or removing covers may expose you to dangerous voltage or other hazards. Refer all servicing to qualified service personnel.

**20. Damage Requiring Service**

Unplug this product from the wall outlet and refer servicing to qualified service personnel under the following conditions:

- a. When the power-supply cord or plug is damaged.
- b. if liquid has been spilled, or objects have fallen into the product.
- c. If the product has been exposed to rain or water.
- d. If the product does not operate normally by following the operating instructions. Adjust only those controls that are covered by the operating instructions as an improper adjustment of other controls may result in damage and will often require extensive work by a qualified technician to restore the product to its normal operation.
- e. If the product has been dropped or damaged in any way.
- f. When the product exhibits a distinct change in performance-this indicates a need for service.

**21. Replacement Parts**

When replacement parts are required, be sure the service technician has used replacement parts specified by the manufacturer or have the same characteristics as the original part.

Unauthorized substitutions may result in fire, electric shock, or other hazards.

**22. Safety Check**

Upon completion of any service or repairs to this product, ask the service technician to perform safety checks to determine that the product is in proper operating condition.

**23. Wall or Ceiling Mounting**

The product should be mounted to a wall or ceiling only as recommended by the manufacturer.

**24. Heat**

The product should be situated away from heat sources such as radiators, heat registers, stoves, or other products (including amplifiers) that produce heat.

# WICHTIGE SICHERHEITSANWEISUNGEN

## 1. Alle Anweisungen lesen.

Vor Betrieb des Erzeugnisses sollten alle Sicherheits- und Bedienungsanleitungen gelesen werden.

## 2. Die Anweisungen aufbewahren.

Die Sicherheits- und Bedienungsanleitungen sollten für den zukünftigen Bezug aufbewahrt werden.

## 3. Warnungen beachten.

Die Warnungen auf dem Erzeugnis und in den Bedienungsanleitungen sollten beachtet werden.

## 4. Anweisungen befolgen.

Alle Bedienungsanleitung- und Verwendungsanweisungen sollten befolgt werden.

## 5. Reinigung

Den Stecker des Geräts vor Reinigung aus der Steckdose ziehen. Keine flüssigen Reinigungsmittel oder Aerosolreiniger verwenden. Zum Reinigen einen feuchten Lappen verwenden.

## 6. Zubehör

Nur vom Hersteller des Erzeugnisses empfohlenes Zubehör verwenden, da es sonst zu Störungen kommen kann.

## 7. Wasser und Feuchtigkeit

Dieses Erzeugnis nicht in der Nähe von Wasser verwenden - z.B. in der Nähe einer Badewanne, eines Waschbeckens, einer Küchenspüle, eines Waschzubehörs, in einem nassen Keller, in der Nähe eines Schwimmbeckens usw.

## 8. Aufstellung

Das Erzeugnis nicht auf einen unstabilen Wagen, Stand, Dreifuß, Träger oder Tisch stellen. Das Erzeugnis kann sonst herunterfallen und ein Kind oder einen Erwachsenen schwer verletzen. Außerdem kann das Gerät schwer beschädigt werden. Nur mit einem Wagen, Stand, Dreifuß, Träger oder Tisch verwenden, der vom Hersteller empfohlen oder mit dem Erzeugnis verkauft worden ist. Für jegliche Anbringung sollten die Anweisungen des Herstellers befolgt werden, und das vom Hersteller empfohlene Anbringungszubehör sollte verwendet werden.

## 9. Eine Kombination von Erzeugnis und Wagen sollte vorsichtig bewegt werden.

Schneller Halt, übermäßige Krafteinwirkung und unebene Oberflächen können Umkippen der Kombination von Erzeugnis und Wagen verursachen.

## 10. Ventilation

Schlitze und Öffnungen im Gehäuse dienen der Ventilation. Sie sind für zuverlässigen Betrieb des Gerätes und Schutz vor Überhitzung erforderlich und dürfen nicht blockiert oder abgedeckt werden. Die Öffnungen sollten niemals dadurch blockiert werden, daß das Gerät auf ein Bett, ein Sofa, einen Teppich oder eine ähnliche Oberfläche gestellt wird. Das Gerät sollte nur dann in Einbauinstallation wie in einem Bücherschrank oder einem Gestell verwendet werden, wenn angemessene Ventilation vorgesehen ist bzw. Die Anweisungen des Herstellers befolgt worden sind.

## 11. Stromversorgung

Dieses Erzeugnis sollte nur an der auf dem Typenschild angegebenen Stromversorgungsart betrieben werden. Wenn Sie nicht sicher sind, was für eine Stromversorgung Sie haben, so wenden Sie sich bitte an Ihren Erzeugnishändler oder an das lokale Elektrizitätswerk. Beziehen Sie sich für Batteriebetrieb oder andere Stromquellen vorgesehene Erzeugnisse bitte auf die Bedienungsanleitungen.

## 12. Erdung oder Polarisierung

Dieses Erzeugnis ist mit einem Schutzkontaktstecker mit drei Leitern ausgerüstet, mit einem Erdungskontakt. Dieser Stecker paßt nur in eine schuko-Steckdose. Dies ist eine Sicherheitsmaßnahme. Wenn Sie den Stecker nicht in die Steckdose stecken können, so wenden Sie sich bitte an Ihren Elektriker, damit er die veraltete Schutz des Schutzkontaktsteckers unwirksam macht.

## 13. Netzkabelschutz

Netzkabel sollten so verlegt werden, daß möglichst nicht darauf getreten wird und daß sie nicht eingeklemmt werden, mit besonderer Beachtung der Kabel an Stackern, Verlängerungskabeln und dem Austritt des Kabels aus dem Erzeugnis.

#### **14. Blitzschlag**

Für zusätzlichen Schutz des Erzeugnisses während eines Gewitters oder bei Nichtverwendung für lange Zeit den Stecker aus der Steckdose ziehen. Dies verhindert Beschädigung durch Blitzschlag und Netzspannungsschläge.

#### **15. Überlastung**

Wandsteckdosen, Verlängerungskabel und eingebaute Bequemlichkeitssteckdosen nicht überlasten, da dies Feuer oder elektrischen Schlag verursachen kann.

#### **16. Eindringen von Fremdkörpern und Flüssigkeit**

Niemals Objekte irgendwelcher Art durch die Öffnungen in das Gerät schieben, da diese unter hoher Spannung stehende Teile berühren oder kurzschließen können, wodurch es zu Feuer oder elektrischem Schlag kommen kann. Niemals Flüssigkeiten irgendwelcher Art auf das Erzeugnis verschütten.

#### **17. Entflammbare und explosive Substanzen**

Vermeiden Sie Verwendung dieses Erzeugnisses an Orten mit Gasen bzw. entflammbaren oder explosiven Substanzen in der direkten Umgebung.

#### **18. Starke Stöße oder Vibrationen**

Setzen Sie das Erzeugnis beim Transport nicht starken Stößen oder Vibrationen aus.

#### **19. Wartung**

Versuchen Sie nicht, dieses Erzeugnis selbst zu warten, da Sie sich durch Öffnen bzw. Entfernen von Abdeckungen hohen Spannungen und sonstigen Gefährdungen aussetzen können.

Beziehen Sie sich für jegliche Wartung auf qualifiziertes Wartungspersonal.

#### **20. Beschädigung, die Wartung erfordert**

Ziehen Sie den Stecker dieses Erzeugnisses aus der Steckdose und wenden Sie sich an qualifiziertes Wartungspersonal, wenn eine der folgenden Bedingungen vorliegt:

- a. Wenn das Netzkabel oder der Stecker beschädigt ist.
- b. Bei Eindringen von Flüssigkeit oder Fremdkörpern in das Gerät.
- c. Wenn das Erzeugnis Regen oder Wasser ausgesetzt worden ist.
- d. Wenn das Erzeugnis bei Befolgen der Bedienungsanleitungen nicht normal funktioniert.

Nur die Regelelemente verstellen, die in den Bedienungsanleitungen behandelt werden, da unangemessene Einstellung anderer Regelelemente Beschädigung verursachen kann und oft beträchtliche Arbeit durch einen qualifizierten Techniker erfordert, um das Erzeugnis wieder, zu normalem Betrieb zurückzubringen.

- e. Wenn das Erzeugnis fallen gelassen oder beschädigt worden ist.
- f. Wenn das Erzeugnis eine klare Änderung in der Leistung zeigt-dies weist darauf hin, daß Wartung erforderlich ist.

#### **21. Ersatzteile**

Wenn Ersatzteile erforderlich sind, darauf achten, daß der Wartungstechniker nur die vom Hersteller festgelegten Ersatzteile oder Teile mit den gleichen Charakteristiken wie die ursprünglichen Teile verwendet. Unautorisierte Ersatzteile können Feuer, elektrischen Schlag oder sonstige Gefährdungen verursachen.

#### **22. Sicherheitsprüfung**

Bitten Sie den Wartungstechniker nach der Vervollendung von Wartung oder Reparaturarbeiten an diesem Erzeugnis um die Durchführung von Sicherheitsprüfungen, um zu bestimmen, daß das Erzeugnis im angemessenen Betriebszustand ist.

#### **23. Anbringung an der Wand oder an der Decke**

Das Erzeugnis sollte nur entsprechend den Empfehlungen des Herstellers an einer Wand oder an der Decke angebracht werden.

#### **24. Wärme**

Das Erzeugnis sollte fern von Wärmequellen wie Radiatoren, Heizwiderständen, Öfen und anderen Wärme erzeugenden Erzeugnissen (einschließlich Verstärkern) aufgestellt werden.

# MISES EN GARDE IMPORTANTES

## 1. Lire les instructions

Lire toutes les instructions de sécurité et de fonctionnement avant de faire fonctionner l'appareil.

## 2. Conserver ces instructions

Conserver les instructions de sécurité et de fonctionnement à des fins de référence ultérieure.

## 3. Tenir compte des avertissements

Tous les avertissements qui figurent sur l'appareil et dans le mode d'emploi devront être respectés.

## 4. Observer les instructions

Observer toutes les instructions de fonctionnement et d'utilisation.

## 5. Nettoyage

Avant de procéder au nettoyage, débrancher l'appareil de la prise secteur. Ne pas utiliser de produits de nettoyage liquides ou en aérosol.

Nettoyer l'appareil avec un chiffon humide.

## 6. Fixations

Ne pas utiliser de fixations non recommandées par le fabricant de l'appareil car elles pourraient être source de danger.

## 7. Eau et humidité

Ne pas utiliser l'appareil à proximité d'eau-par exemple près d'une baignoire, d'un lavabo, d'un évier ou d'un bac à lessive, dans un sous-sol humide, ou près d'une piscine, etc.

## 8. Accessoires

Ne pas placer l'appareil sur un chariot, un socle, un pied, un support ou une table instables. L'appareil pourrait tomber, blessant grièvement des enfants ou des adultes, et étant sérieusement endommagé.

Utiliser exclusivement le chariot, le socle, le pied, le support ou la table recommandés par le fabricant, ou vendus avec l'appareil. Pour tout montage de l'appareil, respecter les instructions du fabricant, et utiliser à cette fin l'accessoire de montage recommandé par le fabricant.

## 9. L'appareil monté sur son chariot devra être déplacé avec précaution.

Des arrêts brusques, une force excessive et des surfaces irrégulières pourraient provoquer le renversement de l'ensemble appareil-chariot.

## 10. Ventilation

Les fentes et les ouvertures du coffret sont prévues pour la ventilation ainsi que pour garantir un fonctionnement en toute sécurité de l'appareil et le protéger de toute surchauffe, et ces ouvertures ne devront donc être ni obstruées ni recouvertes. Ne jamais obstruer les ouvertures en plaçant l'appareil sur un lit, un sofa, un tapis ou toute surface similaire. Ne jamais placer l'appareil dans un support confiné, par exemple une bibliothèque ou une étagère, sans ventilation suffisante ou sans respecter les instructions du fabricant.

## 11. Sources d'alimentation

L'appareil devra être alimenté exclusivement sur le type d'alimentation indiqué sur l'étiquette signalétique. Si l'on n'est pas sûr du type d'alimentation du local, consulter le revendeur de l'appareil ou la compagnie d'électricité locale. Pour les appareils qui fonctionnent sur batterie ou sur d'autres sources, voir le mode d'emploi.

## 12. Mise à la terre ou polarisation

L'appareil est doté d'une fiche trifilaire avec mise à la terre, dont la troisième broche assure la mise à la terre. Cette fiche ne rentrera que dans les prises trifilaires de mise à la terre. Ceci est une mesure de sécurité. Si la fiche ne rentre pas dans la prise, faire remplacer la prise défectueuse par un électricien.

Ne pas rendre vaine la mesure de sécurité assurée par cette prise avec mise à la terre.

## 13. Protection du cordon d'alimentation

Acheminer les cordons d'alimentation de façon qu'on ne risque pas de marcher dessus ou de les coincer sous un objet placé dessus ou contre eux.

Faire particulièrement attention aux fiches des cordons, à la proximité des prises, et à l'endroit où ils ressortent de l'appareil.



#### **14. Foudre**

Pour renforcer la protection de l'appareil pendant un orage, ou si l'on s'en éloigne ou qu'on reste longtemps sans l'utiliser, le débrancher de la source d'alimentation. Ceci permettra d'éviter tout dommage de l'appareil dû à la foudre et aux surtensions de ligne.

#### **15. Surcharge**

Ne pas surcharger les prises, rallonges et prises multiples car cela pourrait entraîner un risque de feu ou de choc électrique.

#### **16. Pénétration d'objets et de liquides**

Ne jamais enfoncer d'objets d'aucune sorte dans les ouvertures de l'appareil car ils pourraient toucher des points de tension dangereuse ou court-circuiter des pièces, ce qui pourrait provoquer un feu ou un choc électrique. Ne jamais renverser de liquide d'aucune sorte sur l'appareil.

#### **17. Substances inflammables et explosives**

Eviter d'utiliser l'appareil en présence de gaz, ainsi qu'à proximité immédiate de substances inflammables et explosives.

#### **18. Chocs ou vibrations violents**

Lorsqu'on transporte l'appareil, ne pas le soumettre à des chocs ou des vibrations violents.

#### **19. Réparations**

Ne pas tenter de réparer l'appareil soi-même car le fait d'ouvrir ou de retirer les caches risque d'exposer l'utilisateur à des tensions dangereuses notamment. Confier toute réparation à un personnel qualifié.

#### **20. Dommages nécessitant réparations**

Débrancher l'appareil de la source d'alimentation et confier les réparations à un personnel qualifié dans les cas suivants:

- a. Lorsque le cordon d'alimentation ou sa fiche sont endommagés
- b. Si du liquide s'est renversé sur l'appareil ou que des objets sont tombés dedans
- c. Si l'appareil a été exposé à la pluie ou à l'eau.
- d. Si l'appareil ne fonctionne pas normalement lorsqu'on observe les instructions d'utilisation.

Ne régler que les commandes couvertes par le mode d'emploi ; en effet, un réglage incorrect des autres commandes pourrait entraîner des dommages et nécessiteront souvent des travaux de réparation coûteux par un technicien qualifié pour remettre l'appareil en état de marche.

- e. Si l'appareil est tombé ou qu'il a été endommagé.
- f. Si l'appareil affiche une nette modification de ses performances, cela signifie qu'il a besoin d'être réparé.

#### **21. Pièces de rechange**

Si l'on a besoin de pièces de rechange, veiller à ce que le technicien de réparation utilise exclusivement les pièces de rechange spécifiées par le fabricant ou des pièces ayant les mêmes caractéristiques que les pièces d'origine. Les pièces de rechange non autorisées risquent de provoquer un feu, un choc électrique et autres dangers.

#### **22. Vérification de sécurité**

Après tout travail d'entretien ou de réparation de l'appareil, demander au technicien de réparation d'effectuer les vérifications de sécurité pour s'assurer que l'appareil est en bon état de marche.

#### **23. Montage au mur ou au plafond**

L'appareil ne pourra être monté au mur ou au plafond que de la manière recommandée par le fabricant.

#### **24. Chaleur**

Eloigner l'appareil des sources de chaleur, telles que radiateurs, appareils de chauffage, cuisinières, et de tout produit engendrant de la chaleur (y compris les amplificateurs).

# IMPORTANT NOTICE

## **For USA**

These products have been tested and found to comply with the limits for a Class A digital device, pursuant to Part 15 of the FCC Rules. These limits are designed to provide reasonable protection against harmful interference when the equipment is operated in a commercial environment. This equipment generates, uses, and can radiate radio frequency energy and, if not installed and used in accordance with the instruction manual, may cause harmful interference to radio communications. Operation of this product in a residential area is likely to cause harmful interference in which case the user will be required to correct the interference at his own expense.

## **WARNING**

Changes or modifications not expressly approved by Hitachi Kokusai Electric responsible for compliance could void the user's authority to operate the equipment.

## **For Canada**

This product does not exceed the class A/class B limits for radio noise emissions from digital apparatus as set out in the radio interference regulations.  
Le présent appareil n'émet pas de bruits radioélectriques dépassant les limites applicables aux appareils numériques de classe A prescrites dans le règlement sur le brouillage radioélectrique édicté par le ministère des communications du Canada.

# Contents

Outline and features .....	1
Warnings and cautions when using .....	2
Facility names and functions .....	3
Filter selection .....	4
White and black balance adjustment .....	8
Electronic shutter setting .....	13
Function menu.....	14
Specifications .....	33
Service information.....	35



# Outline and features

The DK-H100 is a high-performance special application HDTV/SD camera.

The camera is ideal for graphic stands point of view and remote observation applications.

With its 2.3million pixels 3-CCD, the DK-H100 provides outstanding performance. The camera offers sharper and cleaner HD images due to its 14-bit A/D converters and Hitachi's implementation of the latest digital processing technology. The camera achieves outstanding high sensitivity and a low vertical smear specifications.

## Outstanding Features

### ■High resolution

The latest generation 2/3-inch 2.3 million pixels CCD with micro lenses and digital multi speed signal processing circuits provide a horizontal resolution performance of 1100 TV lines (luminance channel).

### ■Latest generation Digital technology

The brand new, power efficient Digital Signal Processor LSI with 65nm design rule and 14-bit analog-to-digital conversion provide very faithful video image reproduction and quality.

Digital video processing and encoding provide low interference and high stability.

### ■ High sensitivity and Signal to Noise ratio

Low-noise circuit technology provide a signal to noise ratio of 58dB.

Even at high gain, clear images are obtained with little noise.

The standard sensitivity is F10 at 2000lx and minimum illumination is 0.002lx with F1.4 lens iris stop.

### ■Versatile CCD drive functions

Four modes of shutter operation are provided:

- Five PRESET electronic shutter speeds
- LOCK SCAN to image computer monitors without flicker
- Automatic Electronic Shutter (AES) maintains the video level with a fixed lens F-stop.
- Charge Controlled Frame (CC FRM) offers improved vertical resolution.

### ■Digital processing improves Image Highlight Quality

- Knee saturation and auto-knee  
The auto knee provides a wide dynamic range by dynamically compressing the video level above 100%. Knee saturation restores color saturation to scene highlights above 100%.

- Automatic Skin Tone Detail Circuits

Skin tone detail smoothes and softens facial lines and blemishes without sacrificing overall scene detail, also provides two separate settings that can be used separately or simultaneously.

Automatic Skin tone detail provides an easy and fast means to optimize Skin tone detail.

- Variable Detail Boost Frequency

The detail frequency can be adjusted to provide coarse or fine contours around edges of subjects in the scene thereby reproducing a natural and pleasing picture.

- 12-Vector and Linear Matrix masking

The 12-vector and linear matrix provide the user a wide latitude in subject image color control.

- Skin Tone masking

Skin tone masking provides "fine" "Painting" (hue and saturation) of Skin tones without effecting other colors in the scene.

- Gray Scale Automatic Setup

This "through the lens" automatic setup is uses a standard gray scale chart to automatically setup gain, gamma, black and flare thus saving the video operator time and effort.

- Automatic Shading

Automatic shading corrects white vertical shading at the push of a button.

This function provides separate memory of lens' modulation shading characteristics to optimize the X1 and X2 lens extender positions.

### ■Extensive User-Friendly

- Scene Files

Gain, detail, masking, gamma and other settings can be stored in eight scene file memories.

### ■Viewfinder displays

- Two mode zebra

Menu selection of over-level or between range zebra is provided.

- Safety zone and center mark display

# Warnings and cautions when using

## WARNING

### ■ Viewfinder high voltage

- Do not open the viewfinder cover. There is danger of touching internal high voltage components.

## CAUTION

### ■ Power supply

The specified power supply input voltage of this camera is 12VDC. Be sure to use the designated power supply.

### ■ Do not disassemble or modify

The camera contains precision internal components. Do not open the cover or disturb switches and controls other than designated. There is risk of impaired performance and damage.

### ■ Keep foreign object out of interior

Entry of water, metallic or other foreign materials can cause failure and damage.

### ■ Select use and storage locations carefully

Avoid using or storing the equipment in the following types of locations. Impaired performance and damage can be caused.

- Extremely hot or cold locations (exceeding -10 to 45°C), such as in enclosed vehicles.
- Subject to strong vibration.
- Humid or dusty locations.
- Salt spray or corrosive gases.
- Strong electromagnetic fields (e.g., near TV or radio transmitters).
- Where exposed to rain.

## CAUTION

### ■ Do not cover or otherwise obstruct camera heat dissipation during operation.

- When connecting and disconnecting lens, microphone and other cables, grasp the connector by the body, not the attached cable. Cables can be damaged by pulling on them.

### ■ Note when transporting

When transporting by hand, use the carrying case. If shipping by truck or other means, pack in the carrying case, then use further cushioning and pack in a sturdy carton.

### ■ Cleaning

Use a photographers air blower to clear dust from the lens and filters. Wipe the case with a soft dry cloth. Do not use volatile solvents, as these may deform the materials.

### ■ In event of difficulty

Disconnect from power and contact the nearest Hitachi Kokusai Electric service agency.

## NOTE

### \*\*\*\*\* CCD characteristic phenomena \*\*\*\*\*

The following types of phenomena are innate characteristics of a charge coupled device (CCD) and are not malfunctions. Be aware of these when using a CCD camera for broadcast or other demanding applications.

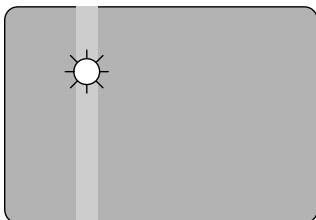

#### Smear

When a bright object is picked up, thin trails appear above and below the image. The effect is more pronounced at high electronic shutter speeds.

#### Fixed pattern

When operate at high temperature, a fixed pattern (vertical stripes, white dots) can appear. The pattern is more easily seen when the camera sensitivity is raised.

# Facility names and functions

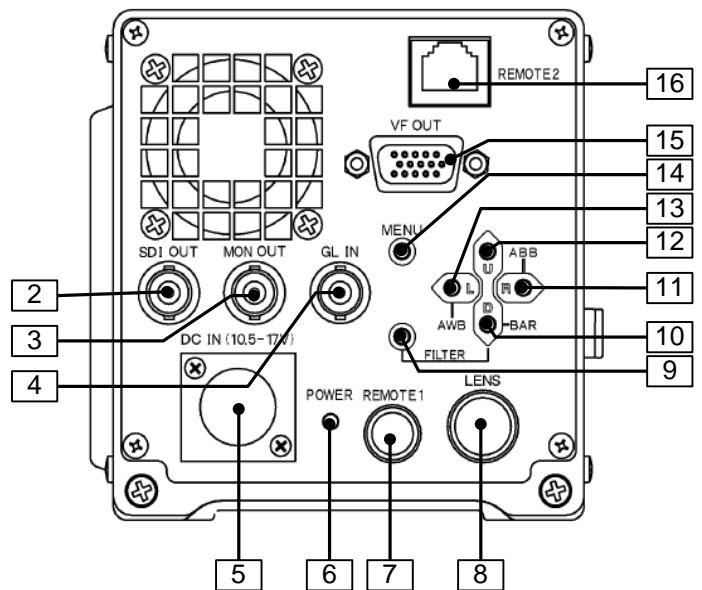
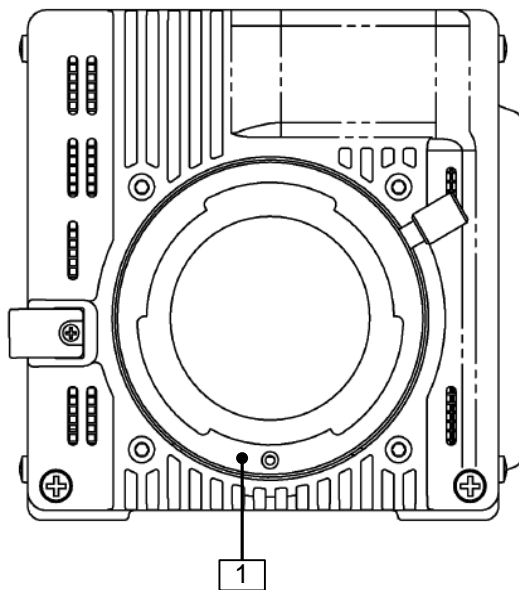

## 1. Lens mount

Bayonet type lens mount.

## 2. SDI OUT connector

HD-SDI/SD-SDI signal output.

## 3. MON OUT connector

HD-SDI/SD-SDI signal output with character.

## 4. GL IN connector

External sync signal input  
(Tri-level sync or Black burst)

## 5. DC IN connector

12V DC is supplied.

## 6. POWER LED

Off: Camera power not supplied.  
Lights (green): Camera power on.

## 7. REMOTE1 connector

Connection for remote control unit or personal computer.

## 8. LENS connector

Connection for lens plug.

## 9. FILTER button

It combines with the L/R button, and the ND filter is controlled.

It combines with the U/D button, and the ECC filter is controlled.

## 10. D button

Menu mode: The menu cursor moves down.

Direct mode: Color bar signal output.

## 11. R button

Menu mode: Change the menu data.

Direct mode: Hold the button depressed for longer than 2 seconds for automatic black balance (ABB) adjustment.

## 12. U button

Menu mode: The menu cursor moves up.

Direct mode: Not used

## 13. L button

Menu mode: Change the menu data.

Direct mode: Hold the button depressed for longer than 2 seconds for automatic white balance (AWB) adjustment.

## 14. MENU button

The function menu is displayed.

## 15. VF OUT connector

Connection for viewfinder.

## 16. REMOTE2 connector

Connection for remote control unit.

# Lens installation

## Lens installation

Install according to the following procedure.

1. Raise the lens lever and remove the mount cap.

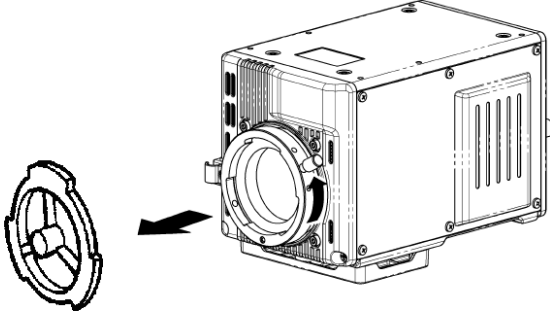

3. Lower the lens lever to secure the lens.

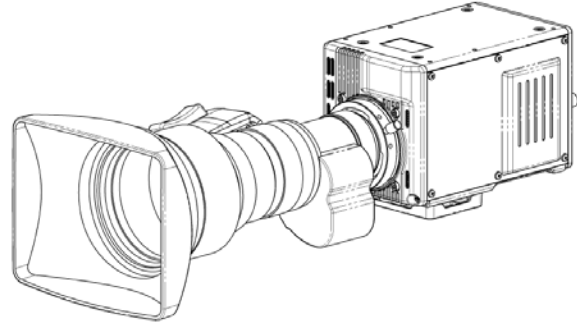

2. Align the lens center mark with the indent at the upper part of the lens mount and install the lens.

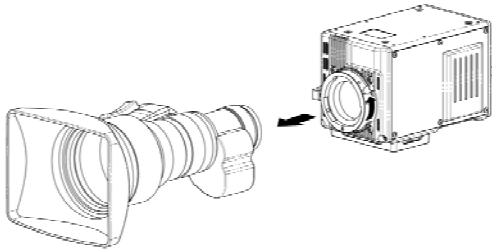

4. Engage the cable with the cable clamp and connect it to the lens connector.

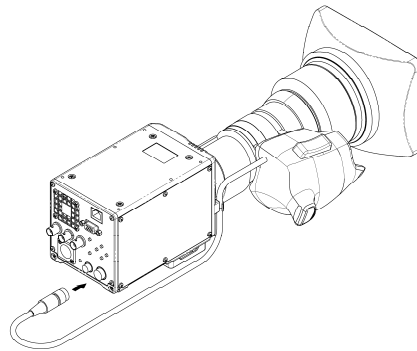

## Notes

The following adjustments may be required according to the type of lens.

1. Lens flangeback,
2. Lens white shading,
3. Lens auto iris speed,
4. Lens iris close limit. (AUTO IRIS menu)



# Lens flangeback adjustment

## Lens flangeback adjustment

When operating a zoom lens, if the focus is not precisely aligned at both the telephoto and wide angle extremes of the lens, the flangeback (distance from the lens mounting plane to the focal plane) is adjusted. This adjustment is generally required only once unless the lens is replaced.

## Adjustment

1. Set the lens iris for manual operation.
2. Set a flangeback adjusting chart about 3 meters distant.

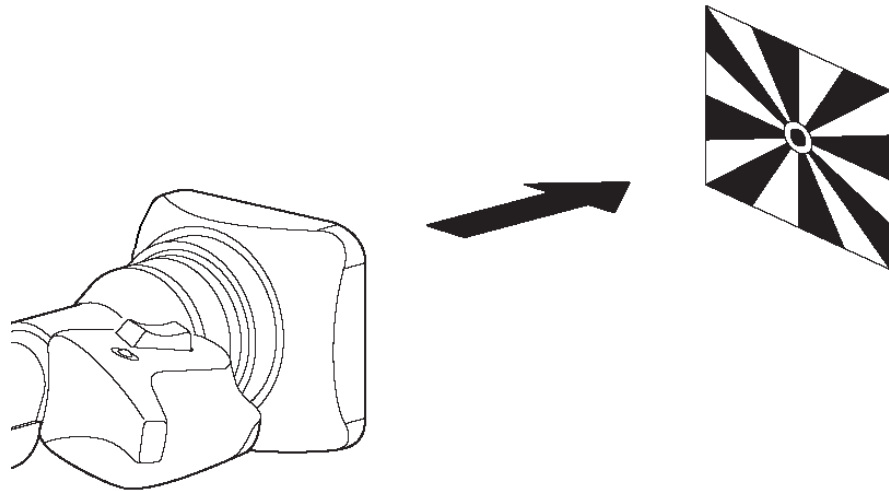

3. Open the iris and adjust the lighting to obtain the correct video output level.  
If the video level is too high, use a ND filter or electronic shutter.
  4. Loosen the FB ring setscrew.
  5. By hand or motor, set the zoom ring to the telephoto position.
  6. Observe the flangeback chart image and turn the distance ring to adjust the focus.
  7. Set the zoom ring to the wide angle position.
  8. Turn the FB ring and adjust the focus. Use care not to turn the distance ring.
  9. Repeat this process until focus is obtained at both telephoto and wide angle settings.
  10. Securely tighten the FB ring setscrew.
- Also, see the lens operating instructions.

# White shading adjustment

## White shading adjustment

White shading adjustment is recommended after replacing the lens.

The adjustment relates to the camera vertical coloration. If the lens includes an extender, the shading can be optimized for both extender on and off modes.

(Vertical coloration refers to an effect whereby the image of an overall white sheet of paper tends toward green at the top and magenta at the bottom, or vice versa.)

## Adjustment

1. Install the lens on the camera.

Be sure to connect the lens cable.

2. Set the electronic shutter to off and the gain to L (0 dB).

3. Set the lens extender to off.

4. When notice flicker on the monitor which occurred by fluorescent or mercury lighting, use sunlight or halogen as the light source.

Using auto iris mode for the lens iris, the iris stop should be between F4 and F11. If necessary, adjust the light source level and keep iris stop position in it (be sure the electronic shutter is off).

5. Open the WHITE SHADING sub menu from MAINTENANCE menu.

6. Shift cursor to WHT SHADING : PUSH > 1 SEC.

7. Hold the R button for about 1 second to adjust white shading. The screen top and bottom cursors flash to indicate automatic white shading adjustment in progress. The cursors extinguish at the end of adjustment.

8. Set the extender (if provided) to on and repeat the above step.

9. Close the Function menu.

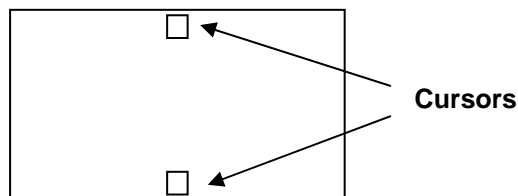
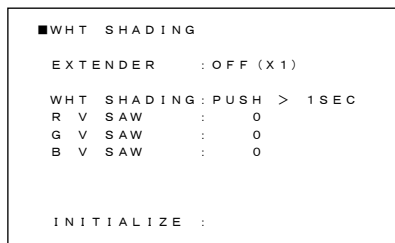

White shading adjustment is completed by the above. The adjustment is stored in a nonvolatile memory and ordinarily does not need to be repeated even if the power is switched off.

### Notes

1. Precise adjustment may not be obtainable with some special lenses.
2. Even after adjustment, some coloration may occur near the open iris setting. This is due to lens and optical system characteristics and is not a malfunction.

# Filter selection

## Filter setting

In order to obtaining correct white balance, the sufficient optical filter selection is required accordance with the scene lighting source. The correct optical filter according to the scene light source needs to be selected in order to obtain correct white balance.

## Operation method

Set the FILTER button and the L/R button.

ND Filter

Filter No.	ND Filter
1	Clear
2	1/4ND
3	1/16ND
4	1/64ND

Set the FILTER button and the L/R button.

ECC Filter

Filter No.	ECC Filter
A	3,200K
B	4,300K
C	5,600K
D	6,300K
E	8,000K

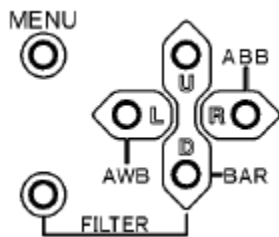

FILTER button + L/R button

→ Clear ⇔ 1/4 ND ⇔ 1/16 ND ⇔ 1/64 ND ←

FILTER button + U/D button

→ 3200K ⇔ 4300K ⇔ 5600K ⇔ 6300K ⇔ 8000K ←

# White and black balance adjustment

## White balance adjustment

White balance will be adjusted to the best effort in the sequence of AWB (auto white balance), ABB (auto black balance), and again AWB.

Readjustment is normally not required even at power off/on.

Be sure to adjust the white balance after changes in the lighting conditions.

White and black balance adjustment progress can be observed from the screen.

## Adjustment

1. Set the W.BAL MODE in the WHITE GAIN menu to MEMORY.

2. Set the FILTER with lighting condition accordingly.

See Optical filter selection in page 7.

3. Place a white pattern at a location subject to the same lighting conditions as the scene. Use zoom function of the lens so that the screen is white. A white object (e.g., cloth, wall) placed near the scene of interest can be used provided the size is adequate (see figure).

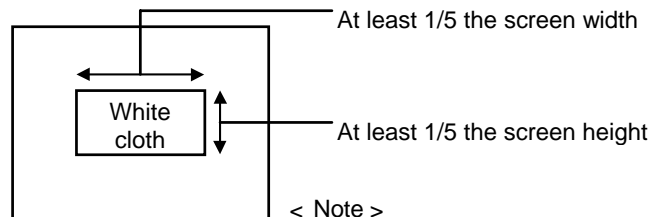

4. Adjust the lens iris.

5. Hold the L button depressed for two second. White balance is adjusted automatically.

6. During adjustment, the following messages appear on the screen.

7. Adjustment is completed in several seconds.



Adjustment in progress

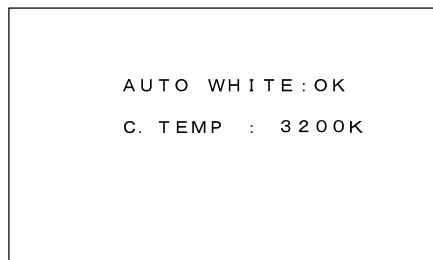

Adjustment complete

# White and black balance adjustment

## Auto white balance error messages

When auto white balance adjustment fails, the following error messages will be displayed on the screen for about 6 seconds.

Message	Cause	Correction
AUTO WHITE:NG CHANGE TO CAM TRY AGAIN	The color bar signal is output.	Press the D button to turn off the color bar signal.
AUTO WHITE:NG CHANGE WHITE BAL TO MEN TRY AGAIN	White balance mode is set to PRESET or AUTO.	Open the WHITE GAIN menu. Set the W.BAL MODE to MEMORY.
AUTO WHITE:NG LOW LIGHT TRY AGAIN	Insufficient lighting for adjustment.	Increase the lighting or set the MASTER GAIN to up. In case the manual iris is using at the lens, adjust the iris stop of the lens. Then repeat white balance adjustment.
AUTO WHITE:NG LEVEL HIGH TRY AGAIN	Excessive lighting for adjustment.	Set the MASTER GAIN to down. In case the manual iris is using at the lens, adjust the iris stop of the lens. Then repeat white balance adjustment.
AUTO WHITE:NG C. TEMP. HIGH CHANGE FILTER TRY AGAIN	Color temperature adjustment is too high.	Change ECC filter and readjust.
AUTO WHITE:NG C. TEMP. LOW CHANGE FILTER TRY AGAIN	Color temperature adjustment is too low.	Change ECC filter and readjust.

When the above error messages appear, correct the settings and repeat white balance adjustment.

# White and black balance adjustment

## Black balance adjustment

Black balance requires adjustment in the following situations.

- Equipment being used for the first time
- Equipment idle for an extended period
- Large change of ambient temperature
- Gamma setting changed

1. Hold the R button depressed for two second. Black balance is adjusted automatically.

2. The displays the following messages during adjustment.

The lens iris is automatically closed.

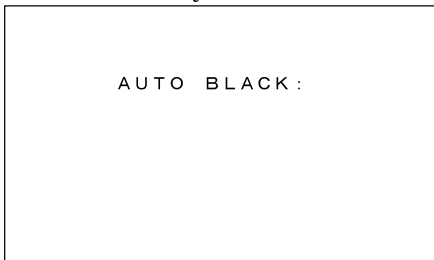

Adjustment in progress



Adjustment complete

3. Adjustment is completed in several seconds and automatically stored in memory.

# White and black balance adjustment

## Auto black balance error messages

When auto black balance adjustment fails, the following error messages appear on the screen for about 6 seconds.

Message	Cause	Correction
AUTO BLACK:NG CHANGE TO CAM TRY AGAIN	The color bar signal is output.	Press the D button to turn off the color bar signal.
AUTO BLACK:NG IRIS NOT CLOSED TRY AGAIN	The Iris is not closed.	See Note 1.
AUTO BLACK:NG ??? TRY AGAIN	Range is exceeded, cannot adjust.	See Note 2.

### Note1

- Observe that the lens connector is engaged and the iris is closed.
- The iris closes automatically to block the light during black balance adjustment.
- During black balance adjustment, the gain circuit is switched automatically.
- Although flicker or noise may appear on the screen, these are not malfunctions.

### Note2

- The lens iris is automatically closed during black balance adjustment. If the iris control is manual, open the iris after adjustment.
- Check the lens connection. If ok, fault is in the lens or the camera. Consult service.

# White and black balance adjustment

## Gray scale auto set up

BLAK, GAIN, FLARE and GAMMA parameter can be adjusted automatically using with the gray scale chart.

Gray scale chart with gate marker in the screen.

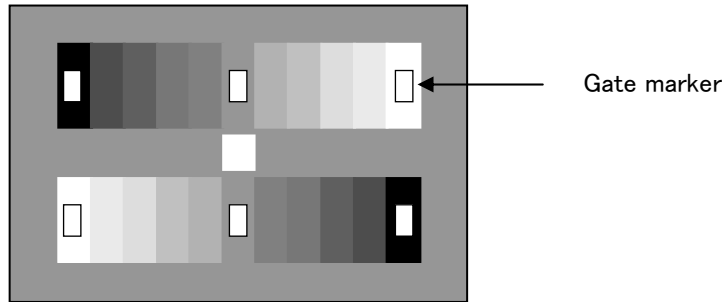

Gray scale auto set up can be accessed from Function menu or the Remote control unit and following message is displayed during auto set up working

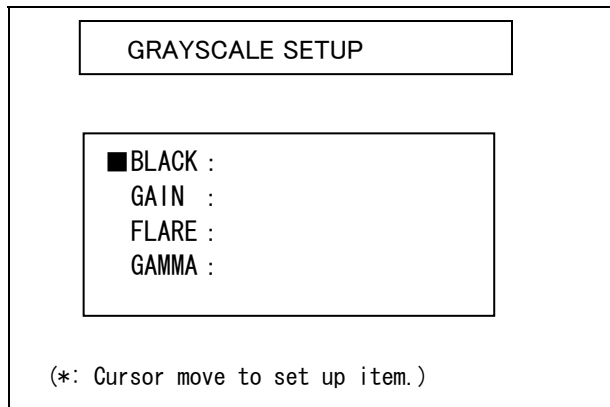

Following messages are displayed as an auto set up result.

CHANGE TO CAM	(Error: Change Bar to CAM)
NOT GRAYSCALE	(Not in the gate marker or no gray chart)
SETUP OK!!!	(Finish set up)
BLACK: NG M.BLACK	(Master black setup error)
GAIN(GAMMA/FLARE) NG R	(R CH error)
GAIN(GAMMA/FLARE) NG G	(G CH error)
GAIN(GAMMA/FLARE) NG B	(B CH error)
GAIN(GAMMA/FLARE) NG R/G	(R&G CH error)
GAIN(GAMMA/FLARE) NG R/B	(R&B CH error)
GAIN(GAMMA/FLARE) NG G/B	(G&B CH error)
GAIN(GAMMA/FLARE) NG R/G/B	(R&G&B CH error)
BREAK OFF	



# Electronic shutter setting

## Shutter modes

The selectable electronic shutter modes and speeds are as follows.

Mode	Shutter speeds	Applications
PRESET	1/100(59.94i), 1/60(50i), 1/250, 1/500,1/1000,1/2000 second	Clear images of quickly moving objects.
LOCK SCAN	59.94i 1/59.94 to 1/11238 second 1.07s(+36dB) to 0.03s(+6dB)  50i 1/50.00 to 1/9375 second 1.28s(+36dB) to 0.04s(+6dB)	When shooting the computer monitor, It's image scroll. Reduce horizontal bar scrolling in images of computer monitor.
CC FRM (Charge Controlled Frame)	1/59.94 second(59.94i) 1/50.00 second(50i)	Set to increase vertical resolution.
AES (Auto Electronic Shutter)	1/59.94 to 1/1000 second (59.94i) 1/50.00 to 1/1000 second (50i)	Set to obtain an always fixed video level when the light is greater than the close limit.

### Note

Camera sensitivity declines as shutter speed increases.

An auto iris lens stop opens at increased shutter speed, while the depth of focus is decreases.

# Function menu

## 1. Operation and menu screen

The function menu screen show up by pressing the MENU button. The menu describes the camera functions and structure with multiple pages. First page of structure is named TOP MENU. This TOP MENU screen is appeared (ON) and disappeared (OFF) by pressing the MENU button.

### TOP MENU

Top menu has the major camera function items and the selection cursor in the screen which cursor can be moved by the U or D button. The cursor is located on the left side of the first line item in TOP MENU right after open it.

Move down the cursor to the major item with the U or D button and press the R button, then the screen change to MAIN MENU.

```
■TOP MENU
COLOR      :>
DETAIL     :>
MAINTENANCE:>
FILE       :>
VF         :>
```

### MAIN MENU

MAIN MENU is categorized into five for each camera operation and grouping to each control items as possible which individual item has marker ▶ on right side of it.

This indicate additional menu screen behind of it which is named to SUB MENU.

<pre>■COLOR MENU MASTER GAIN:&gt; WHITE GAIN:&gt; BLACK/FLARE:&gt; GAMMA      :&gt;&gt; KNEE/CLIP  :&gt;&gt;&gt; MASKING    :&gt;&gt;&gt;&gt;</pre>	<pre>■DETAIL MENU          SCENE 0 DETAIL               :&gt;&gt;&gt; SKIN DTL             :&gt;&gt;&gt; HIGH CHROMA         :&gt;</pre>	<pre>■MAINTENANCE MENU AUTO SETUP :&gt; WHT SHADING:&gt; AUTO IRIS  :&gt; SHUTTER    :&gt; SYSTEM     :&gt; OTHERS     :&gt; CHECK      :&gt;</pre>
<pre>■FILE MENU FILE SELECT:SCENE 0 STORE FILE :SCENE 1 STORE      :  ALL INITIALIZE :</pre>	<pre>■VF MENU VF OUT SEL :COLOR VF DETAIL  :&gt; VF MARKER  :&gt; SIDE PANEL :&gt; VF DISPLAY :&gt; VF ZEBRA   :&gt;</pre>	

### SUB MENU

Move the cursor with the U or D button.

First line of sub menu has the cursor and ◀ or ▶ marker.

Marker ▶ indicate additional sub menu. Press the R button and next sub menu screen show up.

Marker ◀ indicate no additional sub menu behind. This indicate, can go back to main menu with pressing the L button.

Some control items in sub menu has ▶ marker on right side of it. This marker indicate daughter menu screen behind. Move the cursor with the U or D button to these items and press the R button then open the daughter menu screen.

# Function menu

## 2. TOP MENU and MAIN MENU

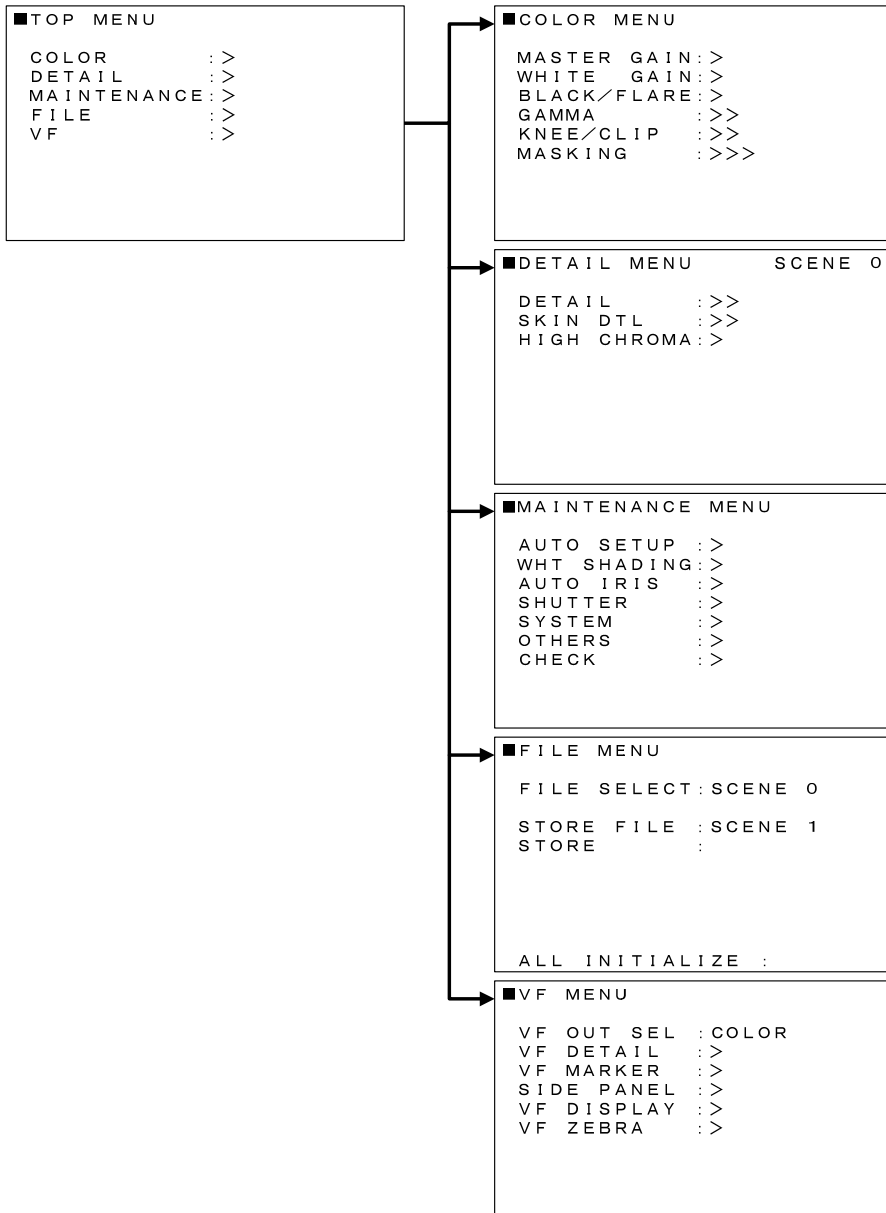

# Function menu

## 3. COLOR MENU (MAIN MENU and SUB MENU)



# Function menu

## 4. DETAIL MENU (MAIN MENU and SUB MENU)

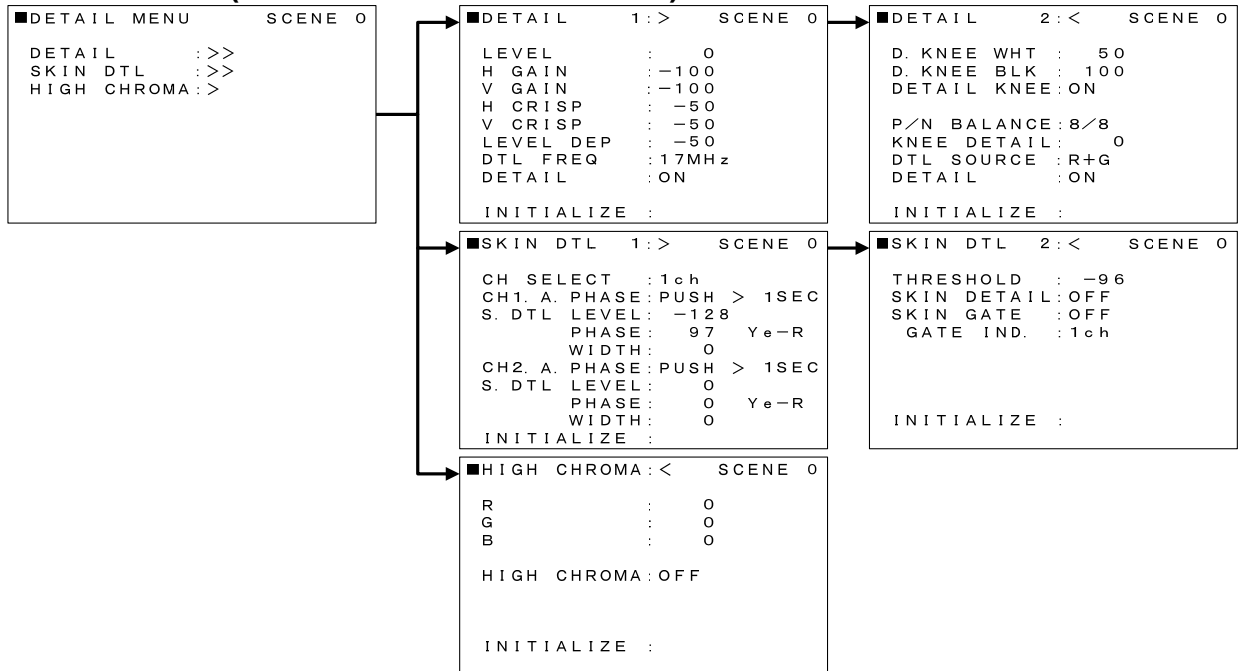

### Note

Typical picture for explaining of DTL functions

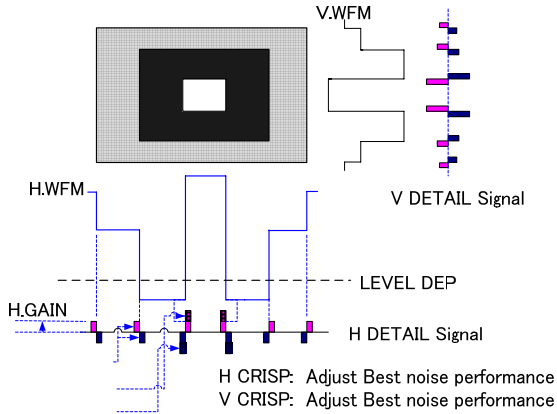

### Note

CH1/CH2 A.PHASE adjustment



When selected CH1 or CH2 A.PHASE item, Skin tone DTL phase auto marker is displayed in the center of the picture. Move the camera shooting position where you want to set Skin tone DTL and push function key one second. Automatically detect video phase in the marker area and setting to two persons of different complexions on the same scene.

# Function menu

## 5. MAINTENANCE MENU (MAIN MENU and SUB MENU)

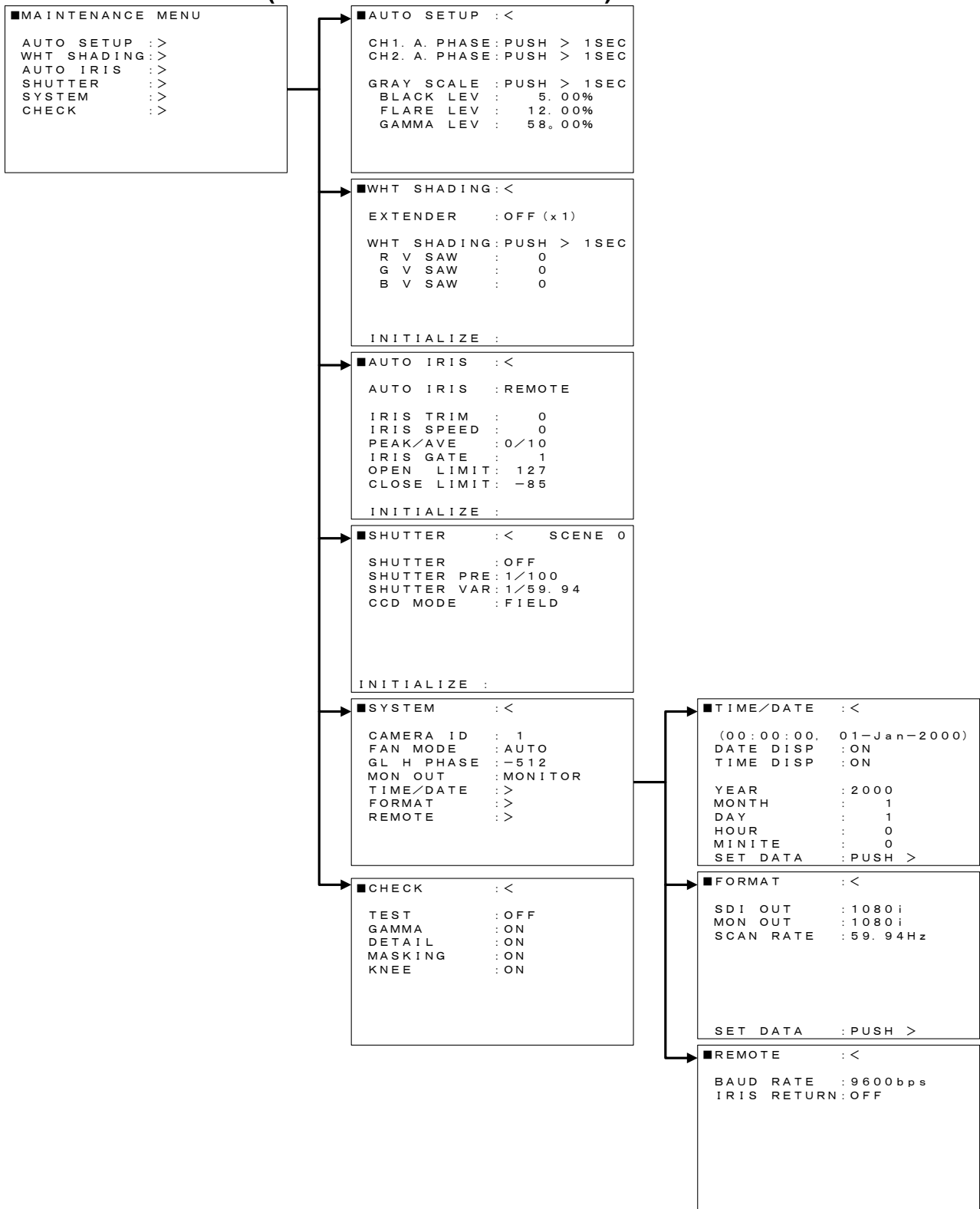

# Function menu

## 6. FILE MENU (MAIN MENU)

```

■FILE MENU
FILE SELECT:SCENE 0
STORE FILE :SCENE 1
STORE
:
ALL INITIALIZE :
    
```

## 7. VF MENU (MAIN MENU and SUB MENU)

```

■VF MENU
VF OUT SEL :COLOR
VF DETAIL  :>
VF MARKER  :>
SIDE PANEL :>
VF DISPLAY :>
VF ZEBRA   :>
    
```

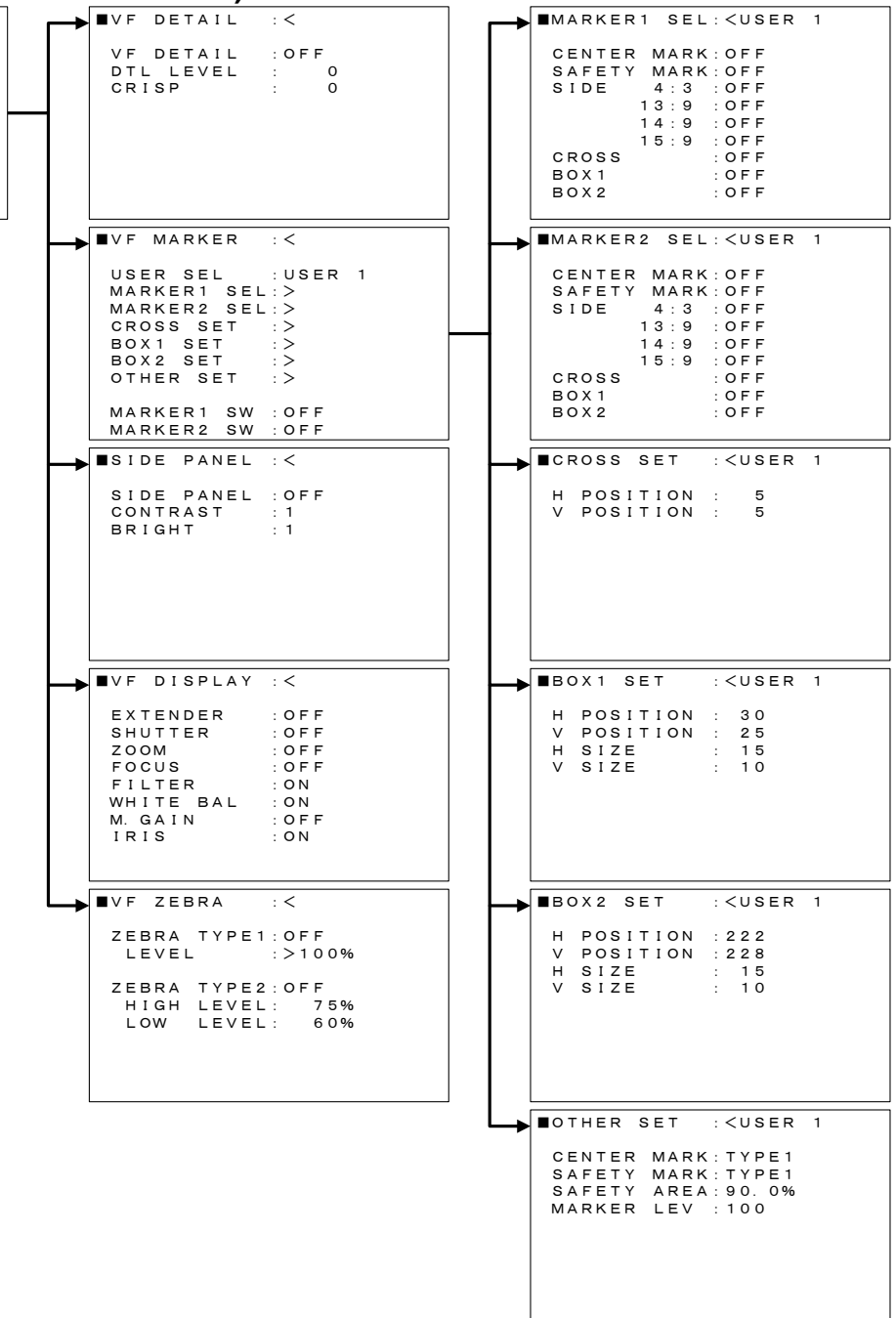

# Function menu

## 8. Each menu item and description

### 8.1 COLOR main menu

■COLOR MENU	SCENE 0
MASTER GAIN :>	
WHITE GAIN :>	
BLACK/FLARE :>	
GAMMA :>>	
KNEE/CLIP :>>	
MASKING :>>>	

Item	Description
MASTER GAIN	Change to MASTER GAIN menu.
WHITE GAIN	Change to WHITE GAIN menu.
BLACK/FLARE	Change to BLACK/FLARE menu.
GAMMA	Change to GAMMA menu.
KNEE/CLIP	Change to KNEE/CLIP menu.
MASKING	Change to MASKING menu.

### 8.1.1 MASTER GAIN sub menu (COLOR MENU)

■MASTER GAIN :<	SCENE 0
PRESET : 0dB	
MODE : PRESET	
AGC LIMIT : +18dB	
LOW SET : 0dB	
MID SET : 3dB	
HIGH SET : 6dB	
INITIALIZE :	

Item	Setting	Initial setting	Description
PRESET	-3dB to 36dB	0dB	
MODE	PRESET, AGC	PRESET	
AGC LIMIT	+1dB to +18dB	+18dB	
LOW SET	-3dB, 0dB	0dB	
MID SET	0dB to +21dB	+6dB	
HIGH SET	+3dB to +36dB	+12dB	
INITIALIZE			Press the L+R buttons to initialize menu items.

### 8.1.2 WHITE GAIN sub menu (COLOR MENU)

■WHITE GAIN :<	SCENE 0
W. BAL MODE : MEMORY	
R GAIN : 0	
G GAIN : 0	
B GAIN : 0	
INITIALIZE :	

Item	Setting	Initial setting	Description
W.BAL MODE	PRESET, MEMORY, AUTO	MEMORY	
R GAIN	-128 to 127	0	Adjust Red Gain.
G GAIN	-128 to 127	0	Adjust Green Gain.
B GAIN	-128 to 127	0	Adjust Blue Gain.
INITIALIZE			Press the L+R buttons to initialize menu items.

### 8.1.3 BLACK/FLARE sub menu (COLOR MENU)

■BLACK/FLARE :<	SCENE 0
R BLACK : 0	
G BLACK : 0	
B BLACK : 0	
R FLARE : 0	
G FLARE : 0	
B FLARE : 0	
FLARE : ON	
M. BLACK : 0	
INITIALIZE :	

Item	Setting	Initial setting	Description
R BLACK	-128 to 127	0	Adjust Red black level.
G BLACK	-128 to 127	0	Adjust Green black level.
B BLACK	-128 to 127	0	Adjust Blue black level.
R FLARE	-128 to 127	0	Adjust Red Flare level.
G FLARE	-128 to 127	0	Adjust Green Flare level.
B FLARE	-128 to 127	0	Adjust Blue Flare level.
FLARE	ON,OFF	ON	FLARE ON and OFF.
M.BLACK	-128 to 127	0	Adjust Master black function.
INITIALIZE			Press the L+R buttons to initialize menu items.



# Function menu

## 8.1.4 GAMMA 1 sub menu (COLOR MENU)

■ GAMMA	1 : >	SCENE 0
R GAMMA	:	0
G GAMMA	:	0
B GAMMA	:	0
TOTAL GAMMA	:	0
GAMMA TABLE	:	4. 0
GAMMA	:	ON
INITIALIZE	:	

Item	Setting	Initial setting	Description
R GAMMA	-128 to 127	0	Adjust Red Gamma
G GAMMA	-128 to 127	0	Adjust Green Gamma
B GAMMA	-128 to 127	0	Adjust Blue Gamma
TOTAL GAMMA	-128 to 127	0	Adjust Total Gamma
GAMMA TABLE	3.0 to 8.0	4.0	Select gamma curve value from table
GAMMA	ON, OFF	ON	GAMMA ON and OFF
INITIALIZE			Press the L+R buttons to initialize menu items.

## 8.1.5 GAMMA 2 sub menu (COLOR MENU)

■ GAMMA	2 : <	SCENE 0
U. GAMMA TBL	:	1 (90%)
ULTRA GAMMA	:	OFF
BLK STR LEV	:	0
BLK STRETCH	:	OFF
INITIALIZE	:	

Item	Setting	Initial setting	Description
U.GAMMA TBL	1(90%), (85%), 3(80%), (75%), 5(70%), 6(65%), 7(50%)	1(90%)	Select ultra gamma curve
ULTRA GAMMA	ON, OFF	OFF	ultra gamma ON and OFF
BLK STR LEV	0 to 11	0	Select gamma curve value from table
BLK STRETCH	ON, OFF	OFF	Black Stretch ON and OFF
INITIALIZE			Press the L+R buttons to initialize menu items.

### Note

Create high quality of picture, user can choose fixed gamma curve from table and also Black Stretch (BLK STR) function bring out detail from dark portion of the picture without affecting middle level keeping with real black level.

## 8.1.6 KNEE/CLIP 1 sub menu (COLOR MENU)

■ KNEE/CLIP	1 : >	SCENE 0
TOTAL KNEE	:	2
R KNEE	:	0
B KNEE	:	0
TOTAL SLOPE	:	13
R SLOPE	:	0
B SLOPE	:	0
KNEE	:	ON
AUTO KNEE	:	OFF
INITIALIZE	:	

Item	Setting	Initial setting	Description
TOTAL KNEE	-128 to 127	2	Adjust Total Knee level
R KNEE	-128 to 127	0	Adjust R individual channel knee level
B KNEE	-128 to 127	0	Adjust B individual channel knee level
TOTAL SLOPE	-128 to 127	13	Adjust Total slope level
R SLOPE	-128 to 127	0	Adjust R individual channel slope level
B SLOPE	-128 to 127	0	Adjust B individual channel slope level
KNEE	ON, OFF	ON	Knee function ON and OFF
AUTO KNEE	ON, OFF	OFF	Auto Knee function ON and OFF
INITIALIZE			Press the L+R buttons to initialize menu items.

## 8.1.7 KNEE/CLIP 2 sub menu (COLOR MENU)

■ KNEE/CLIP	2 : <	SCENE 0
KNEE SAT	:	24
KNEE SAT	:	OFF
WHITE CLIP	:	-16
WHITE CLIP	:	ON
INITIALIZE	:	

Item	Setting	Initial setting	Description
KNEE SAT	-128 to 127	24	Adjust Knee Saturation.
KNEE SAT	ON, OFF	OFF	Knee Saturation function ON And OFF
WHITE CLIP	-128 to 127	0	Adjust White Clip level
WHITE CLIP	ON, OFF	ON	White Clip function ON and OFF
INITIALIZE			Press the L+R buttons to initialize menu items.

### Note

Very bright portion of high light scene is reduced color saturation and changed hue. This Knee Saturation compensates this effect and makes more natural color reproduction.

# Function menu

## 8.1.8 MASKING 1 sub menu (COLOR MENU)

■MASKING	1 : >	SCENE	0
	HUE SAT	HUE SAT	
R	: 0 0	C	: 0 0
Y-R	: 0 0	B-C	: 0 0
Y	: 0 0	B	: 0 0
G-Y	: 0 0	M-B	: 0 0
G	: 0 0	M	: 0 0
C-G	: 0 0	R-M	: 0 0
MASKING	: ON		
INITIALIZE	:		

Item	Setting	Initial setting	Description
R HUE, SAT	-64 to +63	0	Adjust Red hue, saturation
Y-R HUE, SAT	-64 to +63	0	Adjust Yellow - Red hue, saturation
Y HUE, SAT	-64 to +63	0	Adjust Yellow hue, saturation
G-Y HUE, SAT	-64 to +63	0	Adjust Green - Yellow hue, saturation
G HUE, SAT	-64 to +63	0	Adjust Green hue, saturation
C-G HUE, SAT	-64 to +63	0	Adjust Cyan - Green hue, saturation
C HUE, SAT	-64 to +63	0	Adjust Cyan hue, saturation
B-C HUE, SAT	-64 to +63	0	Adjust Blue - Cyan hue, saturation
B HUE, SAT	-64 to +63	0	Adjust Blue saturation
M-B HUE, SAT	-64 to +63	0	Adjust Magenta - Blue hue, saturation
M HUE, SAT	-64 to +63	0	Adjust Magenta hue, saturation
R-M HUE, SAT	-64 to +63	0	Adjust Red - Magenta hue, saturation
MASKING	ON,OFF	ON	Masking ON and OFF
INITIALIZE			Press the L+R buttons to initialize menu items.

## 8.1.9 MASKING 2 sub menu (COLOR MENU)

■MASKING	2 : <	SCENE	0
- LINEAR-			
R-G	: 19	G-R	: 1
B-R	: 0		
R-B	: 3	G-B	: 3
B-G	: 6		
PRESET TYPE	: STANDARD		
CHROMA SAT	: 0		
CHROMA SAT	: OFF		
MASKING	: ON		
INITIALIZE	:		

Item	Setting	Initial setting	Description
LINEAR R-G	-64 to +63	0	Adjust liner matrix R-G parameter offset
LINEAR R-B	-64 to +63	0	Adjust liner matrix R-B parameter offset
LINEAR G-R	-64 to +63	0	Adjust liner matrix G-R parameter offset
LINEAR G-B	-64 to +63	0	Adjust liner matrix G-B parameter offset
LINEAR B-R	-64 to +63	0	Adjust liner matrix B-R parameter offset
LINEAR B-G	-64 to +63	0	Adjust liner matrix B-G parameter offset
PRESET TYPE	STANDARD, ITU-709, SMPTE-240M, SMPTE-WIDE, NTSC, EBU, OFF	STANDARD	
CHROMA SAT	-64 to +63	0	Adjust liner matrix SAT parameter offset
CHROMA SAT	ON,OFF	OFF	Adjust liner matrix SAT parameter
MASKING	ON,OFF	ON	Masking ON and OFF
INITIALIZE			Press the L+R buttons to initialize menu items.

## 8.1.10 MASKING 3 sub menu (COLOR MENU)

■MASKING	3 : <	SCENE	0
-SKIN MASKING-			
S.MASK.SAT	: 0		
S.MASK.HUE	: 0		
SKIN MASK	: OFF		
INITIALIZE	:		

Item	Setting	Initial setting	Description
S.MASK.SAT	-128 to 127	0	Adjust color saturation of the complexion in the scene.
S.MASK.HUE	-128 to 127	0	Adjust hue of the complexion in the scene.
SKIN MASK	ON,OFF	OFF	Skin tone masking ON and OFF
INITIALIZE			Press the L+R buttons to initialize menu items.

# Function menu

## 8.2 DETAIL main menu

■DETAIL MENU	SCENE 0
DETAIL :>>	
SKIN DTL :>>	
HIGH CHROMA:>	

Item	Setting	Initial setting	Description
DETAIL	—	—	Change screen to DETAIL menu.
SKIN DTL	—	—	Change screen to SKIN DTL menu.
HIGH CHROMA	—	—	Change screen to HIGH CHROMA menu.

### 8.2.1 DETAIL 1 sub menu (DETAIL MENU)

■DETAIL	1:>	SCENE 0
LEVEL :	0	
H GAIN :	-100	
V GAIN :	-100	
H CRISP :	-50	
V CRISP :	-50	
LEVEL DEP :	-50	
DTL FREQ :	17MHz	
DETAIL :	ON	
INITIALIZE :		

Item	Setting	Initial setting	Description
LEVEL	-128 to +127	0	Adjust Detail level
H GAIN	-128 to +127	-100	Adjust H. detail gain
V GAIN	-128 to +127	-100	Adjust V. detail gain
H CRISP	-128 to +127	-50	Adjust H detail crisp
V CRISP	-128 to +127	-50	Adjust V detail crisp
LEVEL DEP	-128 to +127	-50	Adjust level dependent of detail
DTL FREQ	13, 14, 15, 16, 17, 18, 19	17 MHz	Set boost frequency of detail
DETAIL	ON,OFF	ON	Detail On and OFF
INITIALIZE	—	—	Press the L+R buttons to initialize menu items.

### 8.2.2 DETAIL 2 sub menu (DETAIL MENU)

■DETAIL	2:<	SCENE 0
D. KNEE WHT :	50	
D. KNEE BLK :	100	
DETAIL KNEE :	ON	
P/N BALANCE :	8/8	
KNEE DETAIL :	0	
DTL SOURCE :	R+G	
DETAIL :	ON	
INITIALIZE :		

Item	Setting	Initial setting	Description
D.KNEE WHT	-128 to +127	50	Positive detail knee adjust
D.KNEE BLK	-128 to +127	100	Negative detail knee adjust
DETAIL KNEE	ON, OFF	ON	DETAIL KNEE ON and OFF
P/N BALANCE	5/8, 6/8, 7/8, 8/8, 8/7, 8/6, 8/5	8/8	Balance adjustment for POS/NEG detail
KNEE DETAIL	-128 to +127	0	Adjust knee detail slope
DTL SOURCE	G,R+G,R+G+B	R+G	Set source signal for detail
DETAIL	OFF, ON	ON	Set On and OFF detail
INITIALIZE	—	—	Press the L+R buttons to initialize menu items.

# Function menu

## 8.2.3 SKIN DTL 1 sub menu (DETAIL MENU)

```

■SKIN DTL 1:> SCENE 0
CH SELECT : 1ch
CH1. A. PHASE: PUSH > 1SEC
S. DTL LEVEL: -128
  PHASE: 97 Ye-R
  WIDTH: 0
CH2. A. PHASE: PUSH > 1SEC
S. DTL LEVEL: 0
  PHASE: 0 Ye-R
  WIDTH: 0
INITIALIZE :
    
```

Item	Setting	Initial setting	Description
CH SELECT	1ch,2ch	1ch	CH selection for skin tone detail
CH1 A.PHASE	—	—	Set CH1 skin tone detail phase *1
CH1 S.DTL	LEVEL	-128 to +127	Adjust CH1 skin tone detail level
	PHASE	-128 to +127 R-Mg, Mg-B, B-Cy, Cy-G, G-Ye, Ye-R	97 Ye-R Set & adjust CH1 skin tone detail phase.
	WIDTH	-128 to +127	0 Range setting of the CH1 skin tone phase
CH2 A.PHASE	—	—	Set CH2 skin tone detail phase. *1
CH2 S.DTL	LEVEL	-128 to +127	0 Adjust CH2 skin tone detail level
	PHASE	-128 to +127 R-Mg, Mg-B, B-Cy, Cy-G, G-Ye, Ye-R	0 Ye-R Set & adjust CH2 skin tone detail phase.
	WIDTH	-128 to +127	0 Range setting of the CH2 skin tone phase
INITIALIZE	—	—	Press the L+R buttons to initialize

\*1: There is same functions in the AUTO SETUP menu and can be accessed from either menu. Refer page 55.

## 8.2.4 SKIN DTL 2 sub menu (DETAIL MENU)

```

■SKIN DTL 2:< SCENE 0
THRESHOLD : -96
SKIN DETAIL: OFF
SKIN GATE : OFF
GATE IND. : 1ch
INITIALIZE :
    
```

Item	Setting	Initial setting	Description
THRESHOLD	-128 to +127	-96	Threshold level for Skin tone Detail set
SKIN DETAIL	ON, OFF	OFF	Skin tone Detail ON and OFF
SKIN GATE	OFF, 1, 2, 1+2	OFF	Display ON and OFF for Skin tone Detail gate
GATE IND.	1ch, 2ch	1ch	Set skin tone Detail gate
INITIALIZE	—	—	Press the L+R buttons to initialize menu items.

## 8.2.5 HIGH CHROMA sub menu (DETAIL MENU)

```

■HIGH CHROMA:< SCENE 0
R : 0
G : 0
B : 0
HIGH CHROMA: OFF
INITIALIZE :
    
```

Item	Setting	Initial setting	Description
R	-128 to +127	0	Adjust detail level in high chrominance Red portion in the scene.
G	-128 to +127	0	Adjust detail level in high chrominance Green portion in the scene.
B	-128 to +127	0	Adjust detail level in high chrominance Blue portion in the scene.
HIGH CHROMA	ON, OFF	OFF	High Chroma detail ON and OFF
INITIALIZE	—	—	Press the L+R buttons to initialize menu items.

# Function menu

## 8.3 MAINTENANCE main menu

```

■MAINTENANCE MENU
AUTO SETUP : >
WHT SHADING : >
AUTO IRIS : >
SHUTTER : >
SYSTEM : >
OTHERS : >
CHECK : >
    
```

Item	Description
AUTO SETUP	Change screen to AUTO SETUP menu.
WHT SHADING	Change screen to WHT SHADING menu.
AUTO IRIS	Change screen to AUTO IRIS menu.
MIC GAIN	Change screen to MIC GAIN menu.
GAIN SET	Change screen to GAIN SET menu.
SHUTTER	Change screen to SHUTTER menu.
SYSTEM	Change screen to SYSTEM menu.
OTHERS	Change screen to OTHERS menu.
CHECK	Change screen to CHECK menu.

### 8.3.1 AUTO SETUP sub menu (MAINTENANCE MENU)

```

■AUTO SETUP : <
CH1. A. PHASE : PUSH > 1SEC
CH2. A. PHASE : PUSH > 1SEC
GRAY SCALE : PUSH > 1SEC
BLACK LEV : 5.00%
FLARE LEV : 12.00%
GAMMA LEV : 58.00%
    
```

Item	Setting	Initial setting	Description
CH1.A.PHASE			Skin tone Auto CH1 phase set. *1
CH2.A.PHASE			Skin tone Auto CH2 phase set. *1
GRAY SCALE			Gray scale Auto set up *2
BLACK LEV	0.0 to 12.35%	5.0%	Black level set
FLARE LEV	0.0 to 24.70%	12.0%	Flare level set
GAMMA LEV	42.20 to 67.70%	58.0%	Gamma level set

\*1: Displayed gate marker in enter of the picture for Skin tone detail Auto set up.

\*2: Displayed 6 gate markers in the picture for Gray scale Auto set up.

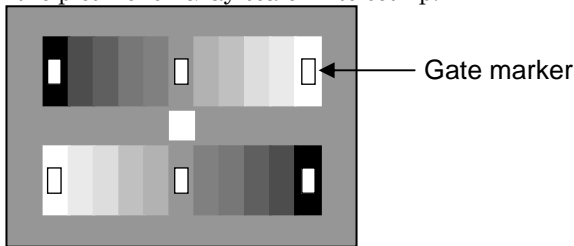

Position the gray scale chart to 6 gate markers

### 8.3.2 WHT SHADING sub menu (MAINTENANCE MENU)

```

■WHT SHADING : <
EXTENDER : OFF (x1)
WHT SHADING : PUSH > 1SEC
R V SAW : 0
G V SAW : 0
B V SAW : 0
INITIALIZE :
    
```

Item	Setting	Initial setting	Description
EXTENDER			Display Lens extender position OFF(X1) : Either of the following. • When the extender is X1. • The lens cable is not connected. ON(X2) : When the extender is X2.
WHT SHADING			Set Auto WHT SHADING
R V SAW	-128 to +127	0	Adjust R V SAW shading
G V SAW	-128 to +127	0	Adjust G V SAW shading
B V SAW	-128 to +127	0	Adjust B V SAW shading
INITIALIZE			Press the L+R buttons to initialize menu items.

# Function menu

## 8.3.3 AUTO IRIS sub menu (MAINTENANCE MENU)

```

■AUTO IRIS : <
AUTO IRIS : REMOTE
IRIS TRIM : 0
IRIS SPEED : 0
PEAK/AVE : 0/10
IRIS GATE : 1
OPEN LIMIT : 127
CLOSE LIMIT : -85
INITIALIZE :
    
```

Item	Setting	Initial setting	Description
AUTO IRIS	REMOTE,AUTO	AUTO	Setting of Iris control mode. *1
IRIS TRIM	-128 to 127	0	Adjust Auto iris output level
IRIS SPEED	-128 to 127	0	Speed control of the Iris response
PEAK/AVE	0/10, 1/9, 2/8, 3/7, 4/6, 5/5	0/10	Setting of Peak & Average detect for Auto iris
IRIS GATE	1 to 6	1	Setting of Auto Iris gate. *2
OPEN LIMIT	0 to 127	127	Adjust limiter value for Auto Iris open
CLOSE LIMIT	-128 to -1	-85	Adjust closing limiter value for Auto Iris
INITIALIZE			Press the L+R buttons to initialize menu items.

\*1: Effect only AUTO selected at the lens side selection switch. If it's selected to MANUAL, drive iris directly.

\*2:

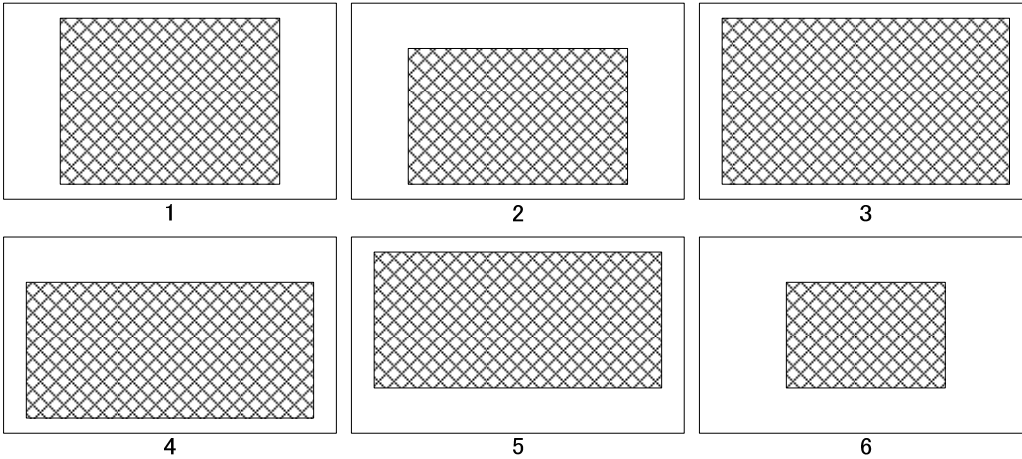

## 8.3.4 SHUTTER sub menu (MAINTENANCE MENU)

```

■SHUTTER : < SCENE 0
SHUTTER : OFF
SHUTTER PRE : 1/100
SHUTTER VAR : 1/59.94
CCD MODE : FIELD
INITIALIZE :
    
```

Item	Setting	Initial setting	Description
SHUTTER	OFF, PRESET, VAR, AES	OFF	
SHUTTER PRE	1/100(59.94i), 1/60(50i) 1/250, 1/500, 1/1000, 1/2000, CCFRM	1/100(59.94i) 1/60(50i)	
SHUTTER VAR	59.94i 1.07s(36dB), 0.53s(30dB), 0.27s(24dB), 0.13s(18dB), 0.07s(12dB), 0.03s(6dB), 1/59.94 to 1/11238 50i 1.28s(36dB), 0.64s(30dB), 0.32s(24dB), 0.16s(18dB), 0.08s(12dB), 0.04s(6dB), 1/50.00 to 1/9375	59.94i 1/59.94  50i 1/50	
CCD MODE	FIELD		
INITIALIZE			Press the L+R buttons to initialize menu items.

# Function menu

## 8.3.5 SYSTEM sub menu (MAINTENANCE MENU)

```

■SYSTEM      : <
CAMERA ID   : 1
FAN MODE    : AUTO
GL H PHASE  : -512
MON OUT     : MONITOR
TIME/DATE   : >
FORMAT      : >
REMOTE      : >
    
```

Item	Setting	Initial setting	Description
CAMERA ID	1 to 99	1	Setting of camera number
FAN MODE	OFF,AUTO,LOW,HIGH	AUTO	Setting of FAN mode
GL H PHASE	-512	-512	Adjustment of GL Phase
MON OUT	MONITOR		
TIME/DATE			
FORMAT			
REMOTE			

## 8.3.6 TIME/DATE sub menu (MAINTENANCE MENU)

```

■TIME/DATE   : <
(00:00:00, 01-Jan-2000)
DATE DISP    : ON
TIME DISP    : ON
YEAR         : 2000
MONTH        : 1
DAY          : 1
HOUR         : 0
MINUTE       : 0
SET DATA    : PUSH >
    
```

Item	Setting	Initial setting	Description
DATE DISP	ON, OFF	ON	The date is displayed at the colorbar.
TIME DISP	ON, OFF	ON	The time is displayed at the colorbar.
YEAR	2000 to 2099	-	Not affected by all initialize.
MONTH	1 to 12	-	Not affected by all initialize.
DAY	1 to 31	-	Not affected by all initialize.
HOUR	0 to 23	-	Not affected by all initialize.
MINUTE	0 to 59	-	Not affected by all initialize.
SET DATA			Press the R button to activate the time and date setting

## 8.3.7 FORMAT sub menu (MAINTENANCE MENU)

```

■FORMAT      : <
SDI OUT     : 1080i
MON OUT     : 1080i
SCAN RATE   : 59.94Hz
SET DATA   : PUSH >
    
```

Item	Setting	Initial setting	Description
SDI OUT	59.94i 1080i, 480i(16:9), 480i(4:3) 50i 1080i, 576i(16:9), 576i(4:3)	59.94i 1080i 50i 1080i	
MON OUT	59.94i 1080i, 480i(16:9), 480i(4:3) 50i 1080i, 576i(16:9), 576i(4:3)	59.94i 1080i 50i 1080i	
SCAN RATE	59.94Hz, 50Hz	59.94Hz	
SET DATA			Press the R button to set output format.

## 8.3.8 REMOTE sub menu (MAINTENANCE MENU)

```

■REMOTE      : <
BAUD RATE   : 9600bps
IRIS RETURN : ON
    
```

Item	Setting	Initial setting	Description
BAUD RATE	9600bps, 19200bps	9600bps	
IRIS RETURN	OFF, ON	ON	

# Function menu

## 8.3.9 CHECK sub menu (MAINTENANCE MENU)

```

■CHECK      : <
TEST       : OFF
GAMMA     : ON
DETAIL    : ON
MASKING   : ON
KNEE     : ON
    
```

Item	Setting	Initial setting	Description
TEST	OFF,ON	OFF	TEST signal ON and OFF
GAMMA	OFF,ON	ON	GAMMA function ON and OFF
DETAIL	OFF,ON	ON	DETAIL function ON and OFF
MASKING	OFF,ON	ON	MASKING function ON and OFF
KNEE	OFF,ON	ON	KNEE function ON and OFF

## 8.4 FILE main menu

```

■FILE MENU
FILE SELECT : SCENE 0
STORE FILE  : SCENE 1
STORE      :
ALL INITIALIZE :
    
```

Item	Setting	Initial setting	Description
FILE SELECT	0 to 8,PRESET	0	Selection of file setting
STORE FILE	0 to 8	1	Setting of scene file memory
STORE			Store scene file data to memory
ALL INITIALIZE			Press the L+R buttons to initialize scene file data



# Function menu

## 8.5 VF main menu

```

■VF MENU
VF OUT SEL : COLOR
VF DETAIL  : >
VF MARKER  : >
SIDE PANEL : >
VF DISPLAY : >
VF ZEBRA   : >
    
```

Item	Setting	Initial setting	Description
VF OUT SEL	COLOR Y,R,G,B	COLOR	
VF DETAIL			Change to VF DETAIL menu.
VF MARKER			Change to VF MARKER menu.
SIDE PANEL			Change to SIDE PANEL menu.
VF DISPLAY			Change to VF DISPLAY menu.
VF ZEBRA			Change to VF ZEBRA menu.

### 8.5.1 VF DETAIL sub menu (VF MENU)

```

■VF DETAIL : <
VF DETAIL  : OFF
DTL LEVEL  : 0
CRISP      : 0
    
```

Item	Setting	Initial setting	Description
VF DETAIL	ON,OFF	OFF	VF Detail ON and OFF
DTL LEVEL	-128 to +127	0	Adjust VF detail level
CRISP	-128 to +127	0	Adjust VF detail Crisp.

#### Note

When VF-L8HD or VF-L9HD is used, VF DTL LEVEL is controlled in Peaking volume of the viewfinder.

### 8.5.2 VF MARKER sub menu (VF MENU)

```

■VF MARKER : <
USER SEL   : USER 1
MARKER1 SEL : >
MARKER2 SEL : >
CROSS SET  : >
BOX1 SET   : >
BOX2 SET   : >
OTHER SET  : >
MARKER1 SW : OFF
MARKER2 SW : OFF
    
```

Item	Setting	Initial setting	Description
USER SEL	USER1/ 2/3/4	USER1	MARKER1/2 SEL, CROSS SET BOX1/2 SET, OTHER SET These can do the memory.
MARKER1 SEL			Change to MARKER1 menu.
MARKER2 SEL			Change to MARKER2 menu.
CROSS SET			Change to CROSS SET menu.
BOX1 SET			Change to BOX1 SET menu.
BOX2 SET			Change to BOX2 SET menu.
OTHER SET			Change to OTHER SET menu.
MARKER1 SW	ON, OFF	OFF	It is effective only to install VF-HD500.

# Function menu

## 8.5.3 MARKER1 SEL/ MARKER2 SEL sub menu (VF MENU)

```

■MARKER1 SEL : <USER 1

CENTER MARK : OFF
SAFETY MARK : OFF
SIDE 4 : 3 : OFF
      13 : 9 : OFF
      14 : 9 : OFF
      15 : 9 : OFF
CROSS : OFF
BOX1 : OFF
BOX2 : OFF
    
```

```

■MARKER2 SEL : <USER 1

CENTER MARK : OFF
SAFETY MARK : OFF
SIDE 4 : 3 : OFF
      13 : 9 : OFF
      14 : 9 : OFF
      15 : 9 : OFF
CROSS : OFF
BOX1 : OFF
BOX2 : OFF
    
```

Item	Setting	Initial setting	Description
CENTER MARK	ON,OFF	ON	Center marker ON and OFF.
SAFETY MARK	ON,OFF	ON	Safety Marker ON and OFF.
SIDE	4:3	ON,OFF	Side 4:3 marker ON and OFF
	13:9	ON,OFF	Side 13:9 Marker ON and OFF
	14:9	ON,OFF	Side 14:9 marker ON and OFF
	15:9	ON,OFF	Side 15:9 marker ON and OFF
CROSS	ON,OFF	OFF	Cross marker ON and OFF.
BOX1	ON,OFF	OFF	Box1 marker ON and OFF.
BOX2	ON,OFF	OFF	Box2 marker ON and OFF.

### Note

This safety marker is synchronized with aspect ratio (4:3, 13:9, 14:9, 15:9, OFF (16:9) ) of the Side panel.

## 8.5.4 CROSS SET sub menu (VF MENU)

```

■CROSS SET : <USER 1

H POSITION : 5
V POSITION : 5
    
```

Item	Setting	Initial setting	Description
H POSITION	0 to 255	5	Adjust Vertical line of Cross Marker horizontally.
V POSITION	0 to 255	5	Adjust horizontal line of Cross Marker vertically.

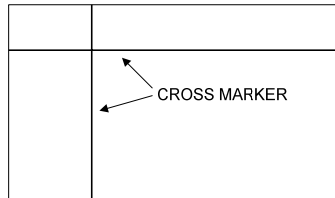

# Function menu

## 8.5.5 BOX1 SET/BOX2 SET sub menu (VF MENU)

```

■BOX1 SET : <USER 1
H POSITION : 30
V POSITION : 25
H SIZE : 15
V SIZE : 10
    
```

Item	Setting	Initial setting	Description
H POSITION	0 to 255	30	Adjust horizontal position.
V POSITION	0 to 255	25	Adjust vertical position.
H SIZE	0 to 255	15	Adjust H. size of the box.
V SIZE	0 to 255	10	Adjust V size of the box.

```

■BOX2 SET : <USER 1
H POSITION : 222
V POSITION : 228
H SIZE : 15
V SIZE : 10
    
```

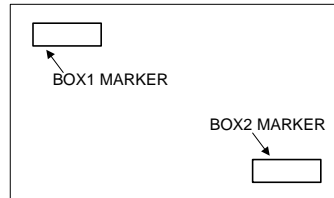

## 8.5.6 OTHER SET sub menu (VF MENU)

```

■OTHER SET : <USER 1
CENTER MARK : TYPE1
SAFETY MARK : TYPE1
SAFETY AREA : 90.0%
MARKER LEV : 100
    
```

Item	Setting	Initial setting	Description
CENTER MARK	TYPE1/2/3/4	TYPE1 *1	Type setting of center marker. *3
SAFETY MARK	TYPE1/2/3	TYPE1 *2	Type setting of safety marker. *4
SAFETY AREA	80.0%, 90.0%, 92.5%, 95.0%	90.0%	Setting of safety area
MARKER LEV	0 to 100	100	Adjustment of marker level

\*1:USER 1:TYPE 1, USER 2:TYPE 2, USER 3:TYPE 3, USER 4:TYPE 4

\*2:USER 1:TYPE 1, USER 2:TYPE 2, USER 3:TYPE 3, USER 4:TYPE 1

\*3:Type setting of center marker

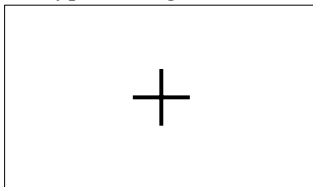

TYPE 1

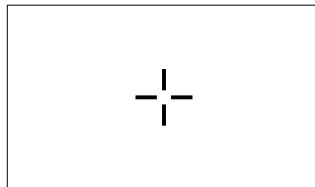

TYPE 2

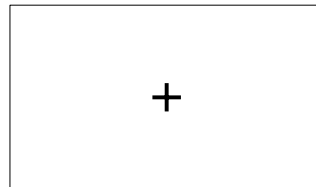

TYPE 3

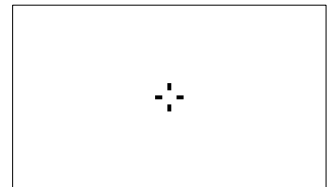

TYPE 4

\*4:Type setting of safety marker

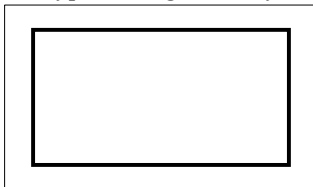

TYPE 1

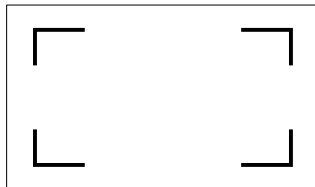

TYPE 2

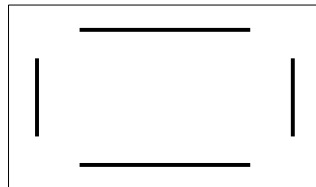

TYPE 3

# Function menu

## 8.5.7 SIDE PANEL sub menu (VF MENU)

```

■SIDE PANEL : <
SIDE PANEL : OFF
CONTRAST   : 1
BRIGHT     : 1
    
```

Item	Setting	Initial setting	Description
SIDE PANEL	OFF, 4:3, 13:9, 14:9, 15:9	OFF	Only when DISP SIZE is 16:9, it is effective.
CONTRAST	1 to 5	1	Set side panel contrast
BRIGHT	1 to 5	1	Set side panel brightness

## 8.5.8 VF DISPLAY sub menu (VF MENU)

```

■VF DISPLAY : <
EXTENDER    : OFF
SHUTTER     : OFF
ZOOM        : OFF
FOCUS       : OFF
FILTER      : ON
WHITE BAL   : ON
M. GAIN     : OFF
IRIS        : ON
    
```

Item	Setting	Initial setting	Description
EXTENDER	ON,OFF	OFF	Display the Extender indicator in VF, ON and OFF
SHUTTER	ON,OFF	OFF	Display the Shutter indicator in VF, ON and OFF
ZOOM	ON,OFF	OFF	Display the Zoom indicator in VF, ON and OFF
FOCUS	ON,OFF	OFF	Display the Focus indicator in VF, ON and OFF
FILER	ON,OFF	ON	Display the Filter indicator in VF, ON and OFF
WHITE BAL	ON,OFF	ON	Display the white balance mode indicator in VF, ON and OFF
M.GAIN	ON,OFF	OFF	Display the M. Gain indicator in VF, ON and OFF

## 8.5.9 VF ZEBRA sub menu (VF MENU)

```

■VF ZEBRA : <
ZEBRA TYPE1 : OFF
LEVEL        : >100%
ZEBRA TYPE2 : OFF
HIGH LEVEL  : 75%
LOW LEVEL   : 60%
    
```

Item	Setting	Initial setting	Description
ZEBRA TYPE1	ON,OFF	OFF	Zebra marker type1 for VF, ON and OFF
LEVEL	75% to 105%	>100%	Adjust limit value of VF zebra type 1
ZEBRA TYPE2	ON,OFF	OFF	Zebra marker type 2 for VF, ON and OFF
HIGH LEVEL	55% to 100%	75%	Adjust maximum value of VF zebra type 2

# Specifications

## DK-H100

CCD	2/3-inch, IT-CCD 2.3 million pixels
Signal format	1080/59.94i, 1080/50i, 480/59.94i, 576/50i
Aspect ratio	16:9 (HD/SD), 4:3 (SD) switchable
Prism	F1.4
Optical Filter	1X motorized filter wheel w/ 4 filter positions (Clear, 1/4 ND, 1/16 ND, 1/64 ND)
ECC Filter	3200 K, 4300 K, 5600 K, 6300 K, 8000K
Lens mount	B4 Bayonet
HD Resolution	1100TVL
HD SNR	Typical 60dB (HD-SDI output decode Y channel Band: 27.5 MHz)
Std Sensitivity	F10@2000lx (1080/59.94i), F11@2000lx (1080/50i) 3200K, 89.9% reflectance
Analog-to-Digital Conversion depth	14-Bit
Minimum illumination	0.002 lx (F1.4/+72dB) +72dB at +36dB GAIN and CCD charge accumulation
Vertical Smear	Typical -130dB
Gain selection	L (low) -3, 0dB M (medium) 0 to 21dB, 3dB steps. H (high) +3 to 36dB, 3dB steps.
Shutter	1/100(59.94i), 1/250, 1/500, 1/1000, 1/2000 (s) 1/60(50i), 1/250, 1/500, 1/1000, 1/2000 (s)
Lock scan	1/59.94 to 1/11238, 1.07s(+36dB) to 0.03s(+6dB) 59.94i 1/50.00 to 1/9375, 1.28s(+36dB) to 0.04s(+6dB) 50i
Geometric distortion	Overall: 0 % (excluding lens characteristics)
Registration Overall	0.01 % (excluding lens characteristics)
Dimensions	99(W) × 105(H) × 155(D) (excluding protrusions)
Power Consumption	approx. 17W (DC12V)
MASS	approx. 1.5 kg (3.3 lbs)
Input & Output	MON OUT:1X BNC HD-SDI or SD-SDI out (Character ON) SDI OUT:1X BNC HD-SDI or SD-SDI out GL IN:1X BNC for Tri-level sync or BB REMOTE1:4-pin Multi connector for remote control panel REMOTE2:8-pin RJ-45 connector for remote control VF OUT:15-pin D-SUB connector for viewfinder LENS:12-pin Multi LENS connector

# Specifications

## Dimensions

•DK-H100

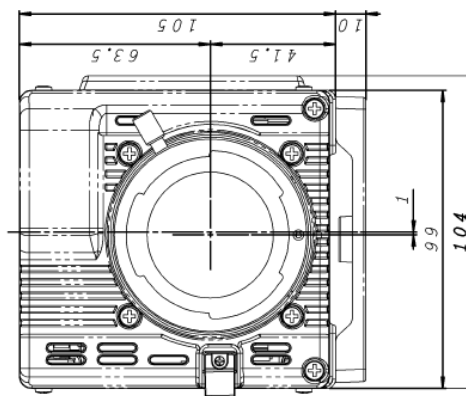
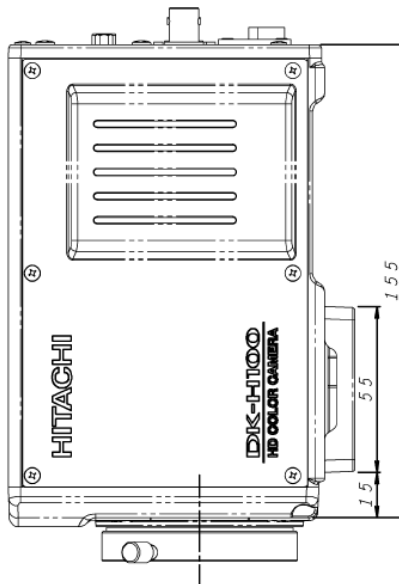
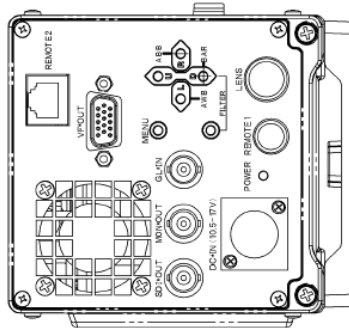
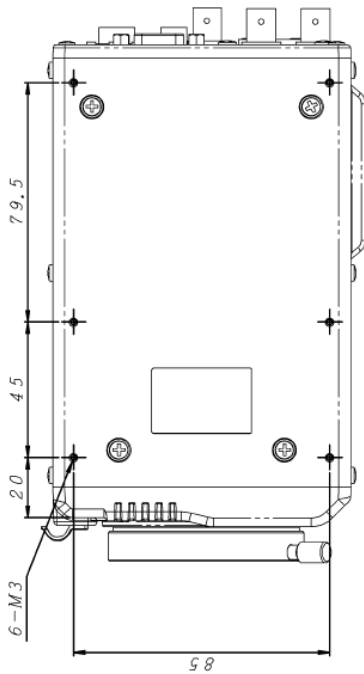

# Service information

## Connector pin diagrams

LENS connector

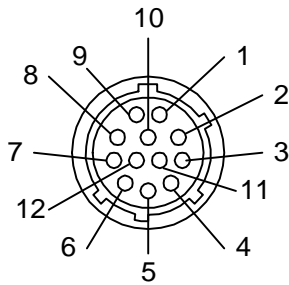

Pin	Signal	Pin	Signal
1	AUX SW	7	IRIS POSITION
2	CALL TRG	8	IRIS A/R
3	GND	9	EXETEND
4	ENF AUTO	10	ZOOM POS
5	IRIS CONTROL	11	F POS / L TX
6	+12V	12	L RX

REMOTE1 connector

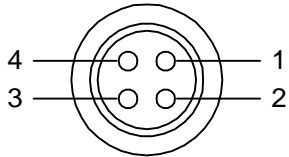

Pin	Signal
1	+12V output
2	SD input
3	SD output
4	SD GND

VF OUT connector

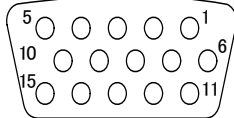

Pin	Signal	Pin	Signal	Pin	Signal
1	Pr OUT	6	GND	11	CPU DATA IN
2	Y OUT	7	Y SHIELD	12	STRB1/R TALLY
3	Pb OUT	8	PEAKING CONT	13	STRB2/G TALLY
4	SYNC OUT	9	+12V OUT	14	CPU DATA OUT
5	VF DET	10	+12V OUT	15	CPU CLK/PEAKING SEL

DC IN connector

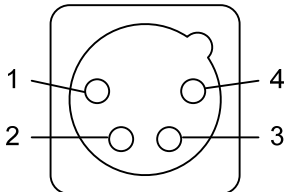

Pin	Signal
1	GND
2	NC
3	NC
4	+12V IN

# Service information

**The solution in the case of having changed into the output mode which the color monitor does not support.**

When it changes to the output mode which the connected color monitor does not support, an image does not appear. And the output mode change by a menu is difficult. Change of the output mode of a camera is in the **state which stopped the camera power supply and pushed the rear button, and is possible by switching on a power supply.** (Output mode is memorized by the memory.)

Please use it, changing the output mode to which a color monitor corresponds.

Button	Video format
D	1080/59.94i
R	1080/50i
MENU + D	480/59.94i
MENU + R	576/50i

