

RGB spectral response characteristics

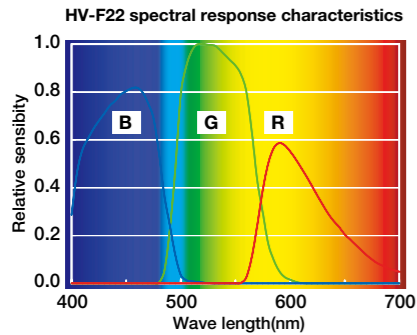

Pin arrangement

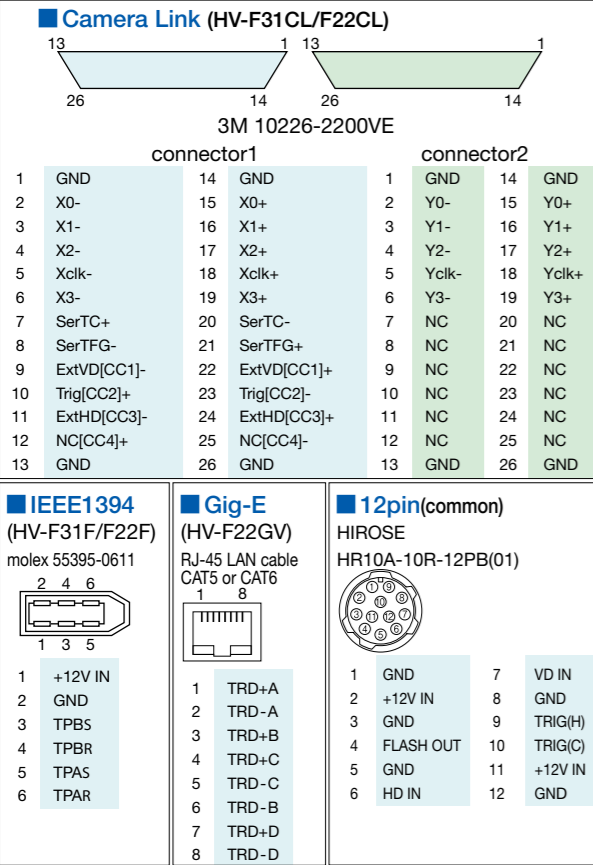

When using lens

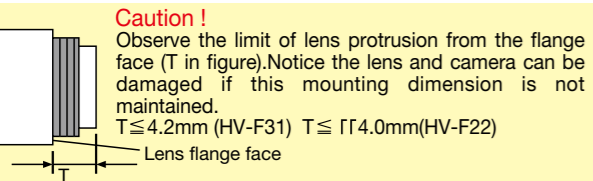

Specifications

	HV-F31	HV-F22
Frame rate	30f/s(F31CL)15f/s(F31F)	15f/s(F22CL)7.5f/s(F22F)
Pixel Clock	28.8MHz	
CCD	1/3"	1/2"
Imaging area	4.76(H)×3.57(V) mm	6.32(H)×4.76(V) mm
Effective pixels	1024(H)×768(V)	1360(H)×1024(V)
Unit cell size	4.65(H)×4.65(V)µm Square pixel	
Gain	AGC(0~+12dB)	
Trigger	One trigger mode	
Shutter	1/100,000~1/30~4(seconds)	1/100,000~1/15~4(seconds)
Ambient	operating 0~+40°C(+32 ° F to +104° F)	
Vibration	29 m/s2 (3 G)	
Shock	490 m/s2 (50 G)	
Power supply	12V nominal Approx.9W	
Dimensions	65(W)×65(H)×130(D) mm	
Mass	Approx. 600 g (21 oz) (not including lens)	

Dimension

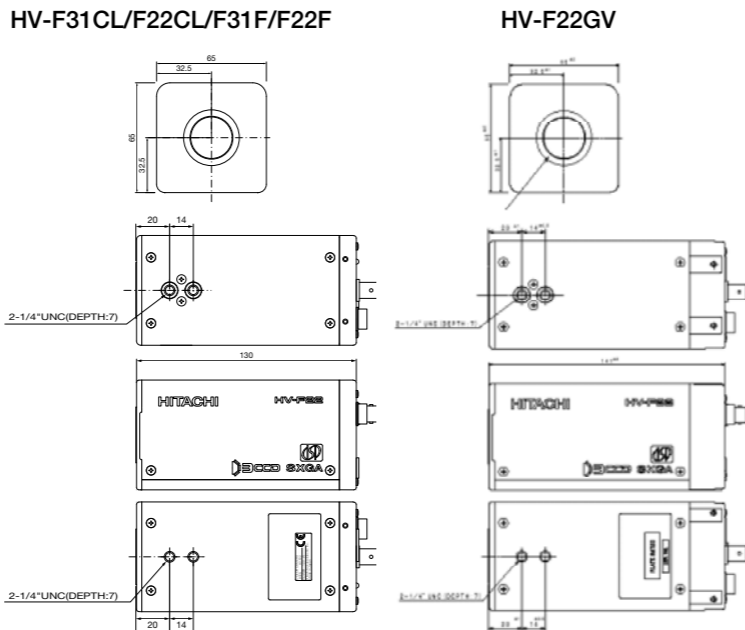

Standard Composition

Camera	1	IEEE1394Cable	1
Operation Manual	1	Junction Box	1
Sample Software	1	(JU-M1A)	

Optional Accessories

Hitachi Kokusai Electric Inc.

HITACHI

High precision digital processing
3CCD progressive scan color camera

HV-F31/F22

IEEE1394

Camera Link

Gig-E



Outline

Camera Link

HV-F31CL : 1/3" XGA (1024×768)
30 frame/second
HV-F22CL : 1/2" SXGA (1360×1024)
15 frame/second

IEEE1394

HV-31F : 1/3" XGA (1024×768)
7.5 frame/second (RGB)
HV-22F : 1/2" SXGA (1360×1024)
7.5 frame/second (RGB)

Gig-E

HV-F22GV : 1/2" SXGA (1360×1024)
15 frame/second

Features

- Excellent color in image capture
- High resolution
- Auto shading correction
- Independent six color adjustment
- IEEE1394 IIDC(Ver. 1.30) / Camera Link
Gig-E

CAUTION: To ensure safe operation, please read the instruction manual before using this product.

These Specifications are subject to change without notice.

Hitachi Kokusai Electric Inc.

Head Office : 14-1, Sotokanda 4-choume, Chiyoda-ku, Tokyo 101-8980, Japan
Phone : +81(0) 3-6734-9432, Fax : +81(0) 3-5209-5942
URL : http://www.hkokusai.com

Hitachi Kokusai Electric (Shanghai) Co., Ltd. Beijing Branch
Room 1413, Beijing Fortune Building, 5 Dong San Huan Bei-Lu, Chao Yang District, Beijing
Phone : +86(0) 10-6590-8755/8756, Fax : +86(0) 10-6590-8757

Hitachi Kokusai Electric America, Ltd. URL : http://hitachikokusai.us
Headquarters and : 150 Crossways Park Drive, Woodbury, New York 11797, U. S. A.
Phone : (+1) 516-921-7200, Fax : (+1) 516-496-3718

Northwest Office : 371 Van Ness Way, Suite 120 Torrance, CA, 90501, U. S. A.
Phone : (+1) 310-328-6116, Fax : (+1) 310-328-6252

West Office : Phone : (+1) 330-334-4115, Fax : (+1) 516-496-3718
Service (+1) 989-345-5379

South Sales : Service (+1) 256-774-3777
Parts Center : Phone : (+1) 516-882-4435, Fax : (+1) 516-921-0993
Latin Sales : Phone : (+1) 516-882-4420, Fax : (+1) 516-496-3718

Hitachi Kokusai Electric Canada, Ltd. URL : www.hitachikokusai.ca
Head Office : 1 Select Avenue Unit#12, Scarborough, Ontario M1V 5J3, Canada
Phone : (+1) 416-299-5900, Fax : (+1) 416-299-0450

Eastern Office : 5795 Chemin St. Francois St. Laurent, Quebec H4S 1B6, Canada
Phone : (+1) 514-332-6687, Fax : (+1) 514-335-1664

Hitachi Kokusai Electric Europe GmbH
Head Office : Weiskircher Straße 88, Jügesheim D-63110 Rodgau, Germany
Phone : +49(0) 6106-69920, Fax : +49(0) 6106-16906
URL : www.hitachi-ke-eu.com
General email address : info@hitachi-ke-eu.com

Hitachi Kokusai Electric U.K. Ltd.
Head Office : Windsor House, Britannia Road, Waltham Cross, Hertfordshire EN8 7NX,
United Kingdom
Phone : +44(0) 845-121-2177, Fax : +44(0) 845-121-2180



CERTIFICATE No.
JMI-0062
ISO 9001/BS 5750P1
EN 29001/JIS Z9901

Example Applications

HV-F31 and HV-F22 are designed for a wide range of applications.

■ Printing Check

Detection of uneven printing

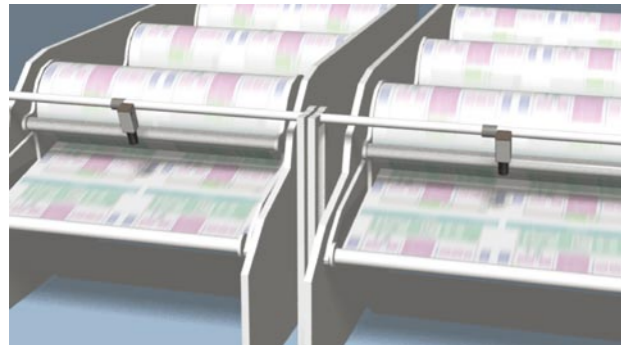

■ Fruit Check

Check on fruit damage and ripening

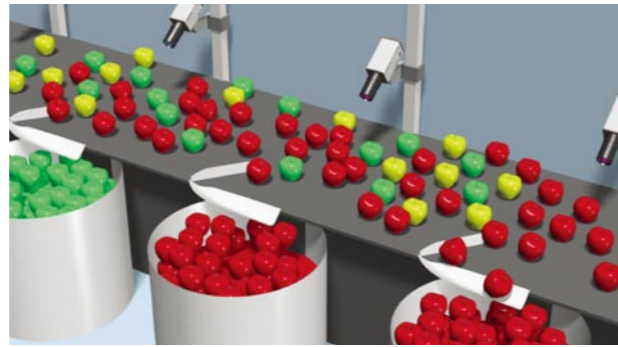

■ Car Body Coating

Check on uneven coating and scratches



■ Biological Microscope

Observation of cells



Merits of 3-CCD Camera

Color Detection (optimum for check on uneven printing and fruits)

Subtle color differences are detectable by processing (emphasis or subtraction) of a specific color using 6-color independent masking.

● Example of improved detection accuracy on apple ripening level

Comparison after subtraction of a red component and emphasis of a yellow component

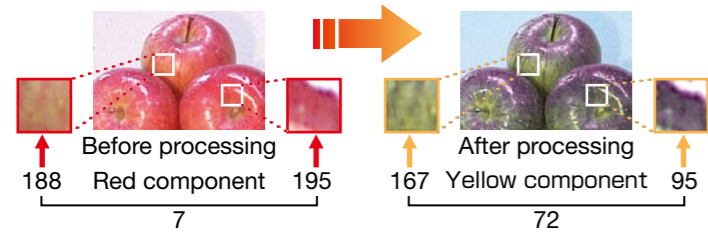

(Note) This camera is not used for output of the above numeral (resolution in 8bit). It is output of a processed image.

● Because arithmetic operation is performed inside the camera, it will not apply a load to the CPU of equipment, so high-speed image processing is ensured.

Auto Shading

Color shading (uneven color) due to lens and lighting can be automatically corrected.



6color Independent Masking

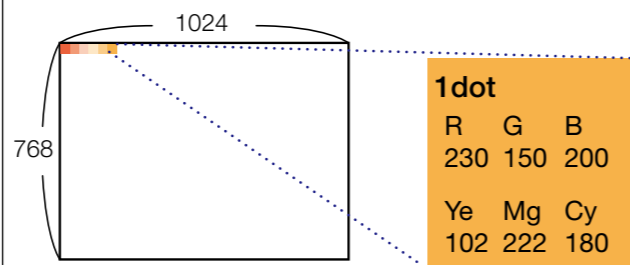

Each color of R,G,B,Ye,Mg and Cy can be represented and changed as an independent numeric value.

Colors are freely changeable and the following are available.

- Detection of a specific color
- Natural color reproduction
- Red alone changed

Color Resolution

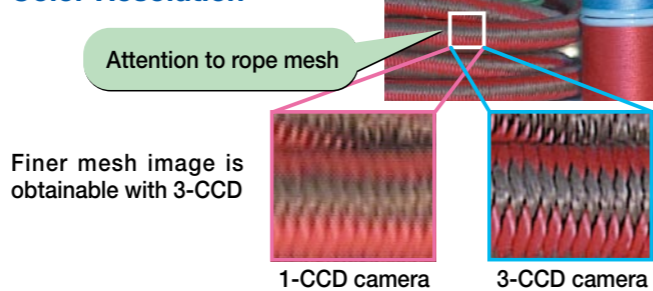

Finer mesh image is obtainable with 3-CCD

Comparison of Interfaces

	HV-F22GV	HV-F31CL/F22CL	HV-F31F/F22F
Interface	Gig-EVision	Camera Link	IEEE1394
Cable length	100m	10m	4.5m
Connector	RJ-45	26PT2 (medium configuration) *Base configuration applicable	6Pin (with lock)
Transmissible Data volume	Approx. 1Gbps	900Mbps (medium configuration) 700Mbps (base configuration)	400Mbps
Remote control	Ethernet API	CameraLink API	IIDC
Rear view			

*Caution For power supply from IEEE1394, contact the sales representative.

IEEE1394

- Features
 - Direct PC connection without using a frame grabber board
 - Small-diameter cable
 - Multiple cameras connectable by use of hub
- Specifications
 - Compatible OHCI, 400Mbps
 - Non-compression
 - Conforming with IIDC1.3

Transmission Format

The HV-F31F/F22F cameras allow transmission of an image with its size changed by remote operation.

HV-F31F					HV-F22F				
Camera mode	Frame Rate	bit/pixel	bit/ch		Camera mode	Frame Rate	bit/pixel	bit/ch	
XGA(1024x768)	YUV	15	16	8	SXGA(1280x960)	YUV	7.5	16	8
	RGB	7.5	24	8		RGB	7.5	24	8
SVGA(800x600) *1	YUV	30	16	8	VGA(640x480)	YUV	30	16	8
	RGB	15	24	8		RGB	30	24	8
XGA(1024x768)	RGB	3.75	48	10	SXGA(1360x1024)	YUV	7.5	16	8
						RGB	1.875	48	10

HV-F31CL					HV-F22GV / F22CL				
Camera mode	Frame Rate	bit/pixel	bit/ch		Camera mode	Frame Rate	bit/pixel	bit/ch	
XGA(1024x768)	RGB	30	30	10	SXGA(1360x1024)	RGB	15	30	10

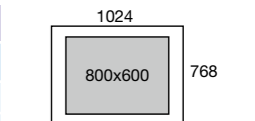

*1: The screen center shown above is effective for SVGA output

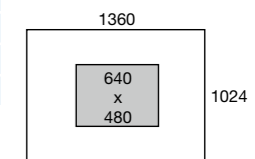

*2: The screen center shown above is effective for VGA output

Application

Various camera functions, such as a Shutter, Gamma, Masking, etc. are available for adjustment through the easy to use GUI software which is included with the camera.

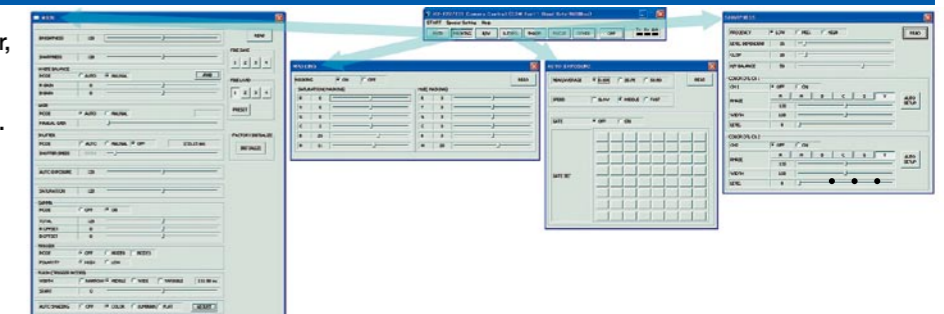

Frame On-demand function

An image can be acquired at a desired timing by external input of a trigger signal.

- One-trigger mode
- When a single trigger pulse is input, exposure will start at the rising edge of the pulse and will end at the falling edge. Then, V.SYNC will be reset immediately followed by output of the image. Pulse width corresponds to the exposure time

